

**American Standard**<sup>®</sup>  
WATER HEATERS

**COMMERCIAL GAS WATER HEATER WITH FLUE DAMPER  
AND ELECTRIC IGNITION SYSTEM WITHOUT FAN MOTOR**

REQUIRES 120V A.C. POWER SUPPLY

**WARNING: !**

If the information in these instructions is not followed exactly, a fire or explosion may result causing property damage, personal injury or death.

- Do not store or use gasoline or other flammable vapors and liquids in the vicinity of this or any other appliance.

What to do if you smell gas:

- Do not try to light any appliance.
  - Do not touch any electrical switch; do not use any phone in your building.
  - Immediately call your gas supplier from a neighbor's phone. Follow the gas supplier's instructions.
  - If you cannot reach your gas supplier, call the fire department.
- Installation and service must be performed by a qualified installer, service agency or the gas supplier.

This appliance shall not be installed in any location where flammable liquids or vapors are likely to be present. Flammable vapors may be drawn to this water heater from other areas of the structure by air currents.

CAUTION THIS WATER HEATER SHOULD NOT BE USED TO HEAT A SPA OR HOT TUB THIS WATER HEATER SHALL NOT BE INSTALLED IN BATHROOMS, BEDROOMS, OR ANY OCCUPIED ROOM NORMALLY KEPT CLOSED.

**WARNING !**

This water heater is equipped for one type gas only. Check the data plate near the control access panel for the correct gas. DO NOT USE THIS WATER HEATER WITH ANY GAS OTHER THAN THE ONE LISTED ON THE DATA PLATE. Failure to use the correct gas can cause problems which can result in DEATH, SERIOUS BODILY INJURY OR PROPERTY DAMAGE. If you have any questions or doubts consult your gas supplier or gas company. Water heaters for bottled, propane or liquefied petroleum gas (LPG) are different from natural gas models.

A natural gas heater will not function safely on bottled, propane or liquefied petroleum gas (LPG) and no attempt should be made to convert a heater from natural gas to any other gas. An odorant is added to the gas used by this water heater.

**IF YOU HAVE QUESTIONS THAT ARE NOT ANSWERED IN THE MANUAL YOU MAY CALL THE TOLL FREE NUMBER 800 900-9063 OR CONTACT US BY EMAIL AT: [engineering@waterheaters.com](mailto:engineering@waterheaters.com). DO NOT CONTACT US BY TELEPHONE OR EMAIL FOR WARRANTY REGISTRATION. YOUR WATER HEATER SERIAL NUMBER IS ALREADY ON FILE. THE WARRANTY IS ACTIVATED AT THE TIME OF PURCHASE. KEEP YOUR RECEIPT TO SHOW TO SERVICE PERSON IF SERVICE IS REQUIRED.**

**DANGER** !



Vapors from flammable liquids will explode and catch fire causing death or severe burns

Do not use or store flammable products such as gasoline solvents or adhesives in the same room or area near the water heater.

**Keep flammable products:**

1. far away from heater,
  2. in approved containers,
  3. tightly closed and
  4. out of children's reach.
- Water heater has a main burner and pilot flame.

**The pilot flame:**

1. is on all the time and
2. will ignite flammable vapors

**Vapors:**

1. cannot be seen,
2. are heavier than air,
3. go a long way on the floor and
4. can be carried from other rooms to the pilot flame by air currents.

**Installation:**

Do not install water heater where flammable products will be stored or used such as a garage, basement, storage area or utility room unless the main burner and pilot flames are at least 18" above the floor. This will reduce, but not eliminate, the risk of vapors being ignited by the main burner or pilot flame.

Read and follow water heater warnings and instructions. If owners manual is missing, contact the retailer or manufacturer.

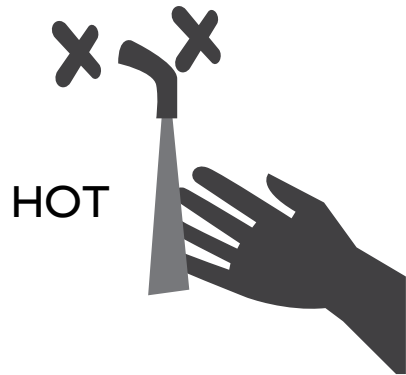

**DANGER** !

Water temperature over 125° F can cause severe burns instantly or death from scalds. Children, disabled and elderly are at highest risk of being scalded.

See instruction manual before setting temperature at water heater.

Feel water before bathing or showering.

Temperature limiting valves are available, see manual.

**TABLE OF CONTENTS**

Danger	2
Consumer responsibilities, pressure build-up, installation information	4
General information, inspect shipment, installation location,	5
Clearance/flooring	5
Clearances from combustibile construction, physical damage protection, Combustion and ventilation air	6
Corrosive atmosphere, water damageidrain pan, venting, draft diverter, vent Piping, drafhoodidamper installation	7
Flue damper, water connections, gas piping	9
Typical installation	10
Installation safety warning I.P. Units, anodes, multiple heater installation	11
Hydrogen gas, temperature and pressure relief valve	12
Electrical, filling heater with water, installation check list before Putting burner in operation	13
Wiring diagram	15
Damper operation sequence/damper operation, natural gas models, L.P. (Propane, bottled) gas models, out of fuel, exposure to water,	16
Instructions for cleaning tank, vacation, combination space	18

Heating/potable heating system,venting system inspection, condensation	<b>18</b>
Before placing heater in operation, operating instructions, to turn off Gas appliance	<b>19</b>
Electronic controller, water temperature regulation, gas pressure, emergency Shutdown instructions, tampering, burner maintenance	<b>21</b>
Water heater sounds, draining the water heater, do not use this water Heater for spas or hot tubs, service must be performed by qualified People, common complaints - check list before calling for service	<b>21</b>
Common complaints - check before calling for service (continued)	<b>25</b>
Replacement parts list	<b>25</b>
Replacement parts illustration	<b>26</b>
Diagram combination space heating /potable water heating system	<b>26</b>

### **Warranty limitations**

The manufacturer of this water heater will not be responsible for tank failures or water heater failures resulting from any of the following. Conditions and may at it's Discretion void the water heater warranty when these conditions result in premature failures of the tank or components...

1. Installations not complying with all local codes.
2. Failures due to undersizing of the water heater and subsequent excessive burner firing.
3. Bad water conditions such as well water with excessive mineral deposits. It is the responsibility of the installer to take what ever steps are required, including the Installation of water softeners, to prevent excessive lime build up and subsequent metal fatigue due to over heating of the tank bottom.
4. Failure to use the hand hole cleanout provided in this water heater to keep lime deposits in the tank bottom from exceeding 2" in height.
5. Installation of multiple heaters in line rather than parallel per the instructions provided on pages 7 and 8 of this manual resulting in excess firing and/or excessive condensation of one or more of the heaters.
6. Failure of the heater or components as a result of improper venting resulting in negative air pressure due to im proper location or overhead fans.
7. Failure of the heater or components caused by chemicals or solvents being stored in the immediate vicinity of the water heater.

## CONSUMER RESPONSIBILITIES

This manual has been prepared to acquaint you with the installation, operation and maintenance of your gas water heater and to provide important safety information.

We urge you to read all instructions thoroughly before attempting installation or operation of your water heater. Keep these instructions for future reference.

The manufacturer of this water heater will not be liable for any damages caused by failure to comply with the installation and operating instructions outlined on the following pages. These instructions are a guide for the correct installation of your water heater. If you lack the necessary skills required or have difficulty following the directions, you should not proceed but get help from a qualified person for that part of the installation you do not understand. Your gas-fired water heater is design-certified by csa international. The installation should conform with the local code or the authority having jurisdiction, or in the absence of such, the national gas code. Ansi z223.1 Nfpa 54. A copy of the code can be purchased from american gas association order processing, 400 n. Capital st. N.W. Washington d.C. 20001 E-mail ordering: [www.Aga.Org](http://www.Aga.Org) fax ordering: 866-816-9444. A rating plate identifying your water heater will be found next to the gas control valve (electronic controller).

### **WARNING !**

#### **CLOSED WATER SYSTEMS**

If the water supply system contains a check valve, back flow preventer or water pressure reducing valve you will have closed water system and the pressure will build up during the water heating cycle. The temperature and pressure relief valve on the water heater will leak during the water heating cycle resulting in loss of energy. It requires both T&P valves and expansion tanks for closed systems. The tank should have a minimum capacity of 3 U.S. gallons.

### **WARNING !**

Failure to provide an expansion tank on the cold water line on a closed system may void the warranty on the water heater.

#### **FOR YOUR SAFETY**

Do not use or store gasoline or any other flammable vapors, liquids, or materials in vicinity of this or any other appliance.

#### **FOR YOUR SAFETY - WHAT TO DO IF YOU SMELL GAS**

- Do not try to light any appliance.
- Do not touch any electrical switch; do not use any phone in your building.
- Immediately call your gas supplier from a neighbor's phone. Follow the gas supplier's instructions.
- If you cannot reach your gas supplier, call the fire department.

### **WARNING !**

Improper installation, adjustment, alteration, service or maintenance can cause injury or property damage. Refer to this manual. For assistance or additional information consult a qualified installer, service agency or the gas supplier.

Please complete the following information at the time of installation. This should be retained and presented along with the warranty in the event a claim is necessary.

MODEL NUMBER: \_\_\_\_\_ TYPE: \_\_\_\_\_  
SERIAL NUMBER: \_\_\_\_\_  
INSTALLATION ADDRESS: \_\_\_\_\_

THIS WATER HEATER HAS BEEN INSTALLED IN ACCORDANCE WITH THESE INSTALLATION INSTRUCTIONS AND LOCAL CODE REQUIREMENTS ON \_\_\_\_\_

INSTALLER: \_\_\_\_\_  
THIS WATER HEATER MUST BE PROPERLY AND REGULARLY MAINTAINED.  
FAILURE TO DO SO WILL VOID THE WARRANTY.

## IMPORTANT

Before proceeding with the installation of this water heater, read and thoroughly understand these installation and operation instructions. If there are any questions, This installation should be performed by a qualified service person.

## GENERAL

**INSPECT SHIPMENT:** Inspect water heater for possible damage. If damaged, notify carrier immediately. Check markings on rating plate to make certain it corresponds with your application.

Read these instructions thoroughly before proceeding with the installation of this new gas-fired water heater. If there is any difficulty understanding all or any part of these instructions, it is recommended that a qualified service person perform the installation.

**NOTICE:** The manufacturer's warranty does not cover damage or injury cause by the use of any energy-saving devices (other than those authorized by the manufacturer) in conjunction with this water heater. The use of unauthorized energy-saving devices may decrease the life of the water heater and endanger life and/or property. The manufacturer will not be held liable for loss or injury resulting from the use of any unauthorized device in conjunction with this water heater.

This water heater has been equipped for use with one type of gas only. Compare the information provided on the rating plate affixed to the front of the water heater, making sure that the gas stated on the rating plate is the same as the gas to be used. **DO NOT ATTEMPT TO USE THIS WATER HEATER WITH ANY GAS OTHER THAN THE TYPE LISTED ON THE RATING PLATE.** Do not attempt to convert this water heater for use with a gas other than the type for which it is equipped. Failure to use the proper gas can create an unsafe condition resulting in property damage, bodily injury or death. Consult local gas supplier or gas company if there are any questions.

For installations in high altitude regions, this water heater must be ordered from the supplier to the manufacturer's specifications for that particular altitude. Contact the company listed on the rating label when ordering high altitude constructed water heaters.

For any questions not covered in this booklet, contact your dealer or write to us at the address shown on the rating plate affixed to the front of the water heater.

This water heater has been designed and manufactured for the express purpose of heating and storing potable water and space heating. See page 12 for space heating instructions. Any use other than this purpose will release the manufacturer from any liability or warranty claims stemming from the issue of this product. Consult local authorities.

## CAUTION !

**DO NOT STORE OR USE FLAMMABLE LIQUIDS, VAPORS, OR MATERIALS IN THE VICINITY OF THIS OR ANY OTHER APPLIANCE.**

## INSTALLATION

**Location -** Select a location accessible to water lines, gas supply (type identified on the rating plate), an adequate open drain, and as close as practical to a chimney or gas vent. When installed, the water heater must be level. To prevent excessive heat loss through water piping, locate the water heater as close as practical to the areas of greatest hot water usage. Do not locate the water heater where lines could be subjected to freezing temperatures.

Adequate clearances shall be provided for easy access to controls by service personnel to enable proper cleaning, servicing and operation of the water heater. Under no circumstances is the front of the water heater to be placed in a position where the burner tray assembly cannot slide out for removal when servicing. **Clearance/Flooring -** If the water heater is installed directly on carpeting, it must be installed on a metal or wood panel which extends beyond the full width and depth of the water heater by at least 3 inches in any direction. If the water heater is installed in an alcove, the entire floor must be covered by the panel. A minimum of 24 inches front clearance shall be provided for inspection and servicing. This water heater may be installed in an alcove on combustible flooring with clearances from combustible materials as shown in Figures 1 and 2.

## CAUTION !

The National Fuel Gas Code (ANSI Z223.1 /NFPA 54) expressly prohibits the following:

- a) Installation of a water heater in a bathroom, bedroom, or any occupied room normally kept closed.

b) Installation of a water heater in a garage, unless the unit is installed so that the burner and ignition devices are at least eighteen (18) inches above floor level and protected to avoid damage by moving vehicle. See Figure 3.

**CLEARANCES FROM COMBUSTIBLE CONSTRUCTION**

	<b>A</b>	<b>B</b>	<b>C</b>	<b>D</b>
D80-125	24"	2"	6"	6"
D80-165	24"	2"	6"	6"
D80-180	24"	2"	6"	6"
D80-199	24"	2"	6"	6"
D100T-199	24"	2"	6"	6"
D100-199	18"	2"	6"	6"
D100-250	18"	2"	6"	6"
D100-270	18"	2"	6"	6"
D100-300	18"	4"	6"	6"
D75-365	24"	2"	6"	6"
D75-399	24"	2"	6"	6"
D80-512	18"	4"	6"	6"

**Remember:** Flammable vapors may be drawn to this water heater from other areas of the structure by air currents.

**Note:** heater shall be located or protected so it is not subject to physical damage by moving vehicles or area flooding.

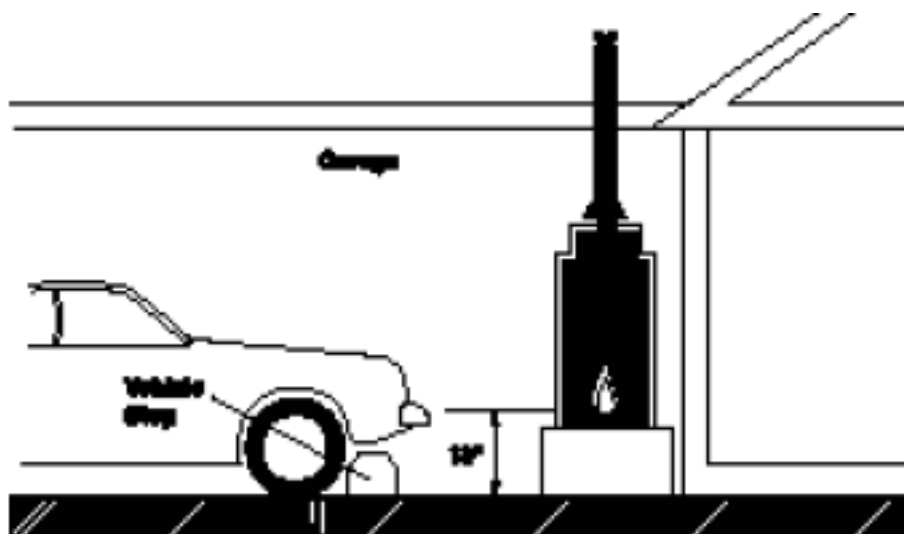

**FIGURE 3:** Typical Installation in Residential Garages (Illustration copyright by the American Gas Association. Used by permission of the copyright holder)

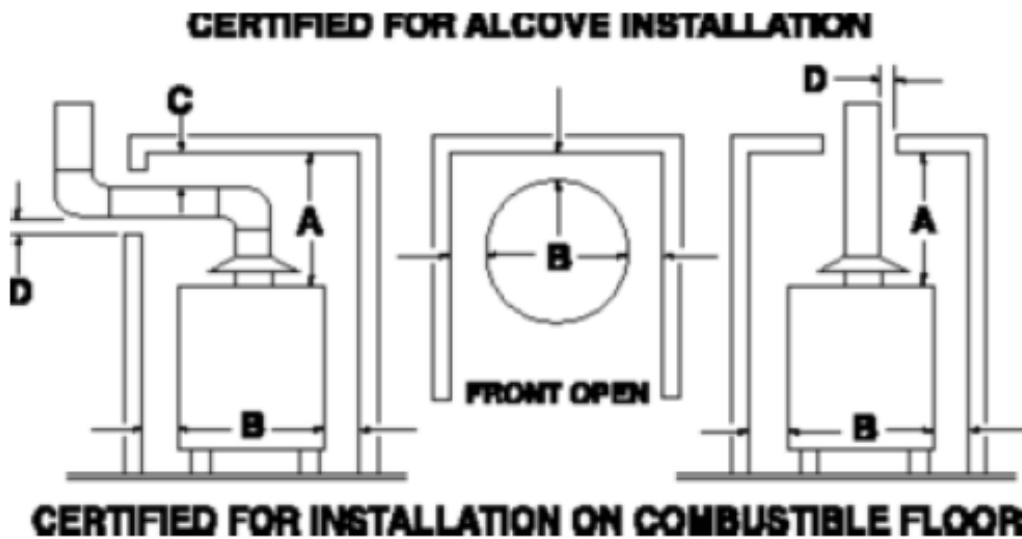
**FIGURE 2**

For installation on combustible flooring, the tank leg thermal break piece identified as part No. 25 on the replacement parts illustration must be installed under each leg. Combustion and Ventilation Air - Provisions must be made for adequate combustion and ventilation air. Details outlining proper air supply for various types of installation are prescribed by the National Fuel Gas Code (ANSI Z-223.1 / NFPA 54) latest edition.

If the water heater is installed in unconfined space within the building, infiltration air may be adequate for proper combustion and ventilation. Buildings of tight construction (weather stripping, caulked, etc.) require additional air from outdoors. If the water heater is installed in a confined space (volume is less than 50 cu. ft. per 1000 BTUH of the total input rating of all gas appliances in that space), air must be supplied through two permanent openings. One opening shall be within 12 inches from the top of the enclosure and one within 12 inches of the bottom. The openings must be protected by metal louvers or 1/4" min. mesh metal screen. The size of the openings are as follows:

1. If the openings communicate directly with an additional room(s) of sufficient volume, each opening shall have a minimum free area opening of 1 sq. in. per 1000 BTUH of the total input rating of all gas appliances in the confined space, but not less than 100 sq. inches.
2. If the openings communicate directly with the outdoors or through vertical ducts with the outdoors, each opening shall have a minimum free area of 1 sq. in. per 4000 of the total rating of all gas appliances in the enclosure.
3. If the openings communicate with the outdoors through horizontal ducts, each opening shall have a minimum free area of 1 sq. in. per 2000 BTUH of the total rating of all gas appliances.

**CAUTION**

The draft diverter relief opening of the water heater and the combustion air inlet must be in the same atmospheric pressure zone. Large exhaust fans in kitchens or other locations can lower the air pressure inside an enclosure and interfere with proper operation and venting of the water heater.

In these cases, the water heater should be installed in a separate room with combustion and ventilation air supplied directly from outdoors as previously described.

**Corrosive Atmosphere** - Water heater corrosion and component failure can be caused by the heating and breakdown of airborne chemical vapors. Spray can propellants, cleaning solvents, refrigeration and air conditioning refrigerants, swimming pool chemicals, calcium and sodium chloride, waxes, and process chemicals are typical compounds which are potentially corrosive. These materials are corrosive at very low concentration levels with little or no odor to reveal their presence.

Products of this sort must not be stored near the water heater, nor should air which is brought in contact with the water heater contain any of these chemicals. Flammable vapors may be drawn by air currents from other areas of the structure to this appliance. If necessary, uncontaminated air should be obtained from remote or outside sources.

**THE WARRANTY ON THIS WATER HEATER DOES NOT COVER DAMAGE CAUSED FROM OPERATION IN A CORROSIVE ATMOSPHERE.**

**Water Damage/Drain Pan** - The water heater should be located in an area where leakage of the tank or connections will not result in damage to the area adjacent to the water heater or to lower floors of the structure. WHEN SUCH LOCATIONS CANNOT BE AVOIDED, A SUITABLE DRAIN PAN MUST BE INSTALLED UNDER THE WATER HEATER HAVING A LENGTH AND WIDTH AT LEAST 3 INCHES GREATER THAN THE DIAMETER OF THE WATER HEATER, A MAXIMUM HEIGHT OF 1-3/4 INCHES, AND BE PIPED TO AN OPEN DRAIN. DO NOT RESTRICT THE FLOW OF COMBUSTION AIR. DRAIN PAN INSTALLATION AND CONSTRUCTION MUST CONFORM TO LOCAL CODES AND ORDINANCES. IF NOT INSTALLED AND OPERATED IN ACCORDANCE WITH THESE INSTRUCTIONS, UNDER NO CIRCUMSTANCES WILL THE MANUFACTURER OF THIS WATER HEATER BE LIABLE FOR ANY WATER DAMAGE OR INJURY IN CONNECTION WITH THIS WATER HEATER.

**DRAFTHOOD LOCATION & FLUE DAMPER INSTALLATION**

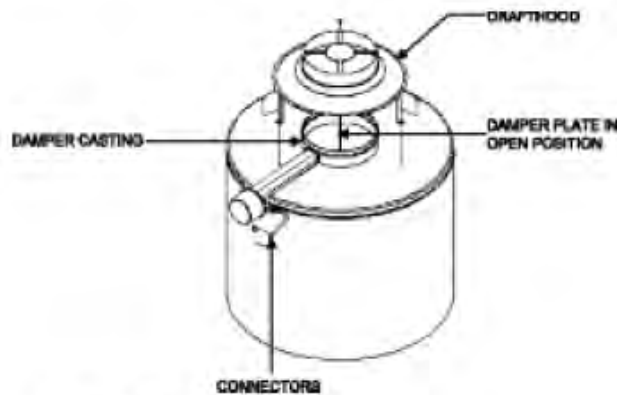

**FIGURE 4**

**VENTING**

**WARNING !**

The installer to check the installation for venting and for spillage all around the draft hood relief opening after five minutes of operation the method to check for flue products spillage should utilize a flame or a match, or candle or smoke or flame from another source such a cigarette or grill lighter wand. The procedure used should be to play the flame or smoke around the perimeter of the draft hood from the outside. If spillage is encountered, it would be manifested by smoke escaping away from the draft hood or by the flame being extinguished while outside of the hood. Good venting would be indicated by smoke and the flames being drawn into the draft hood.

**Vent Size**

<b>Model</b>	<b>Vent Size</b>
D-80-125 AS	5"
D80-165AS, D80-180AS, D80-199AS	6"
D100T-199AS, D100-199AS, D100-250AS, D100-270AS	6"
D100-300AS	7"
D75-365AS, D75-399AS	8"
D80-512AS	10"

Models above may also have prefix "N" (LO-NOX).

\*Note: Some models are equipped with draft hoods with removable reducers for use with larger vents. Vents size must comply with requirements of local codes or in the absence of local codes with the provisions of National Flue Gas Code ANSI Z 223.1 / NFPA 54 latest edition.

**ALL AMERICAN STANDARD COMMERCIAL WATER HEATERS BEGINNING MODEL NUMBERS STARTING WITH A NUMBER OR THE LETTERS N OR D MAY BE INSTALLED AS REPLACEMENTS WITH VENTING THAT MET THE EXISTING CODES AT THE TIME OF THE INSTALLATION OF THE ORIGINAL WATER HEATER.**



**Draft Diverter** - This water heater has been shipped with a draft diverter for which it was designed with reference to the horizontal and vertical planes. If removed, the draft diverter shall be replaced in the same position and secured to the jacket top by the screws with which it was installed.

**Vent Piping** - This water heater must be connected to a masonry chimney or venting system approved by local codes or ordinances. The vent connector used to attach the draft diverter outlet to the chimney or approved vent must be of the same diameter as the draft diverter outlet or larger. For proper venting in certain installations, a larger vent connector may be needed. Consult venting tables in National Fuel Gas Code ANSI Z223.1/NFPA 54 latest or current or local code officials for proper application in your area.

### **CAUTION** !

Do not turn on electrical power to water heater until flue damper is installed and the water heater is filled with water.

Better combustion is achieved by avoiding numerous elbows in the vent piping. Horizontal piping must be sloped upward at least 1/4 inch per linear foot of length. All connections in venting system must be securely fastened with sheet metal screws or other approved method. Check local codes and ordinances.

Failure to install a proper venting system can result in fire, injury, or death.

Flue Damper - Refer to Figure 4 and follow these installation instructions:

1. Remove the damper from the accompanying box shipped within the crate.
2. Locate the collector outlet on top of the water heater. Place the damper over the collector outlet and rotate as necessary to a position in which the damper wiring plug can be fully engaged with the connector on the side of the water heater.
3. Remove clip which holds damper vane closed. The damper will then open by itself.
4. Being certain that the damper vane will travel freely from the "closed" to "open" position, secure the flue damper to the jacket top with sheet metal screws.
5. Connect the damper wiring plug to the connector on the side of the water heater. Note: The plug and connector can only be engaged one way (polarized).
6. The Lighting/Operating instructions are outlined on Page 13. The damper must be in the open position when the water heater main burner is operating (the arrow on the damper plate is in the "up" position when open. Be certain the arrow is in a visible position when installed.)

**Note:** Modification to the flue damper or the draft diverter may result in personal injury, property damage or death. The flue damper and draft diverter are to be placed in position and operation exactly as stated in these instructions without modification.

## **WATER CONNECTIONS**

**Installation-** Refer to Figure 5 for typical installation. Connect the hot and cold water supply to the water heater, hot to the location marked "HOT" and cold to the location marked "COLD".

**Note:** If making cold water connection on top, determine that the dip tube is in place. If sweat connections are used, sweat tubing to adapter before attaching adapter to the top cold water inlet as it may contain a nonmetallic dip tube. When making these connections, use a good grade of pipe joint compound. Be familiar with the location of the shut-off valve in the cold water line feeding the water heater (See Figure 5). If a valve is not present, one shall be installed as shown in Figure 5.

Do not install a check valve or other device that would prevent reverse flow of water ("closed system") unless required by local codes. A closed system will result in frequent operation of the relief valve. Provisions must be made for protection against thermal expansion in the event of a closed system (See Page 1). Warranties do not cover pressure bulges and/or deformities.

This water heater is capable of delivering high temperature hot water at any faucet in the system. Care must be taken whenever using hot water to avoid scalding injury. Certain appliances require high temperature hot water (such as dishwashers and automatic clothes washers). In order to prevent potential scald injury, install an anti-scald tempering valve in the water system.

**GAS PIPING**

Use clean black iron pipe or equivalent material approved by local codes and ordinances for gas piping. Install a groundjoint union in the supply line as close to the water heater as possible. A manual gas shut-off valve should be at least 5 feet above floor level and readily accessible. A drip leg (consisting of a pipe tee, 4 inch nipple, and a cap) should be installed as shown in Figure 5. Make sure the gas supplied to the heater is the same type as listed on the rating plate. **DO NOT ATTEMPT TO USE THIS WATER HEATER WITH ANY GAS OTHER THAN THE TYPE LISTED ON THE RATING PLATE.**

Compound used for the connection of all gas piping should be resistant to the action of liquefied petroleum (L.P.) gases. Apply pipe dope sparingly to the male threads only. **DO NOT** apply pipe dope to the gas valve inlet. Make certain that no pipe dope has become lodged in the inlet screen of the gas valve. This will restrict the flow of gas. When attachment of gas piping to gas valve inlet is made, extreme care must be taken to prevent pipe dope from entering the gas valve inlet and to avoid excessive torque to prevent cracking of the gas valve inlet housing. The suggested maximum torque is 31.5 ft. lbs. The manufacturer of this water heater will not be liable for any damage or injury caused as a result of a cracked gas inlet from excessive torque.

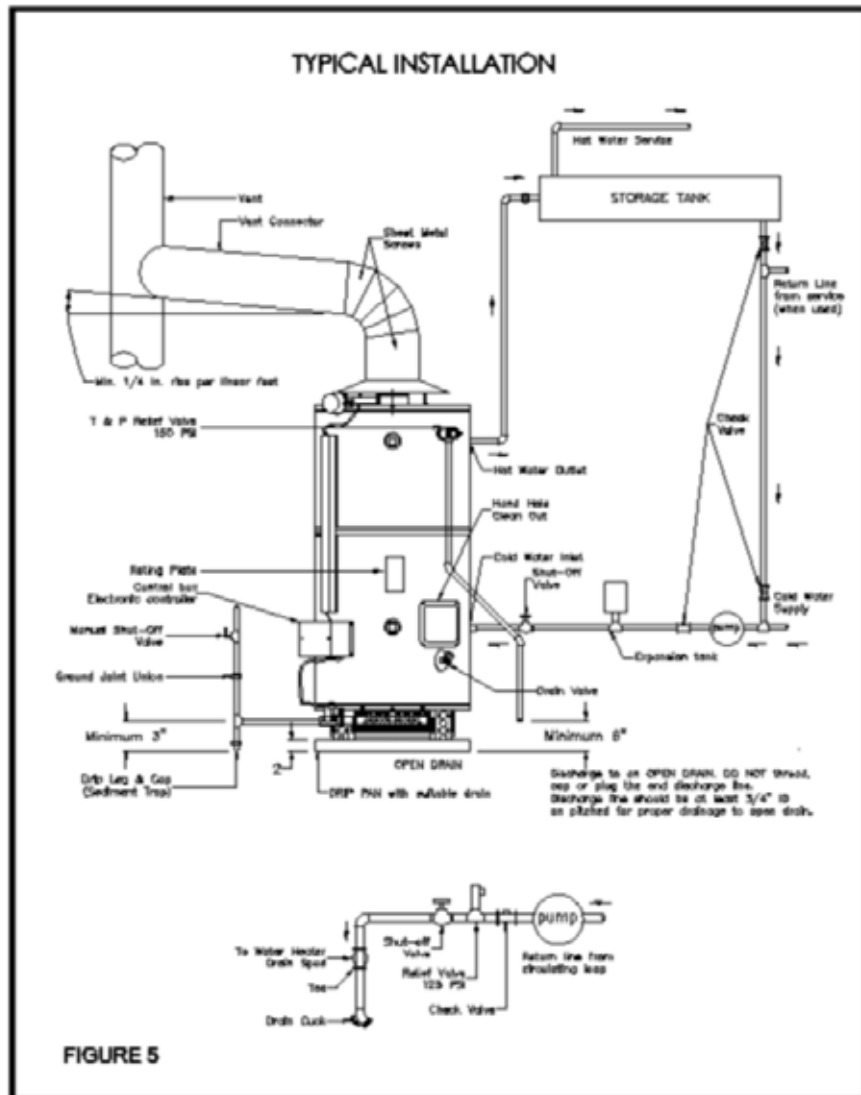

FIGURE 5

After completing all gas connections, check each gas connection and fitting for leaks. Use a soap and water solution or a commercial leak detector fluid. NEVER USE MATCHES OR OPEN FLAME WHEN CHECKING FOR GAS LEAKS.

The water heater and its individual gas shut off valve must be disconnected from the gas supply piping system during any pressure testing or that system at test pressures in excess of 1/2 psig (14" W.C.) or 3.5kPa.

The water heater must be isolated from the gas supply piping system by closing its individual manual shut-off valve during any pressure testing of the gas supply piping system at test pressures equal to or less than 1/2 psig (14" W.C.) or 3.5kPa.

If the gas valve is subjected to pressure exceeding 1/2 psig, the damage to the gas valve could result in an extremely hazardous condition. If this has occurred, the gas valve must be replaced. Contact your dealer for service. It is recommended that all service work be done by a qualified service agency.

**INSTALLATION SAFETY WARNING L.P. UNITS**

Liquified petroleum (L.P.) gas is heavier than air and will remain at floor level if there is a leak. Basements, crawl spaces, closets and areas below ground level will serve as pockets for accumulation of leaking gas. Before lighting, sniff at floor level.

IF YOU SMELL GAS, follow applicable instructions on Front Cover or Page 13.  
DO NOT OPERATE APPLIANCE UNTIL LEAKAGE IS CORRECTED.

**WARNING !**

NEVER OPERATE AN EMPTY OR PARTIALLY FILLED WATER HEATER

**ANODES**

This water heater is supplied with anode rods designed to extend tank life and reduce corrosion. Anodes emit a weak flow of electrical current through the water to protect the tank.

When present in "highly active" water, a "rotten egg" odor may be produced from the gases from the anodes, mixing with the water. This is not the fault of the water heater. Chlorination of the water supply system should minimize this condition. (Consult your telephone directory for local water treatment specialists).

REMOVAL OF AN ANODE ROD WILL VOID THE WARRANTY.

**MULTIPLE HEATER INSTALLATION**

**INSTALLATION DIAGRAMS. INSTALLATIONS WHERE HEATERS ARE MANIFOLDED**

All heaters should have approximately the same input rate. To manifold a high input heater with a low input heater will result in the lower input heater running excessively. It is preferable for all heaters to be the same model.

All heaters must be evenly spaced to provide identical number of turns, length and size of pipes in each manifold. This is absolutely necessary to insure a balanced condition to all heaters in the installation.

INSTALLATION  
Using Back Connect

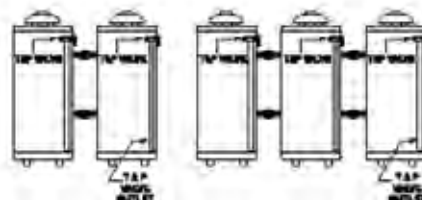
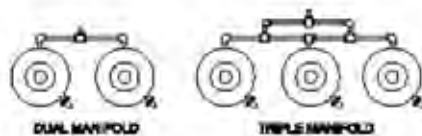

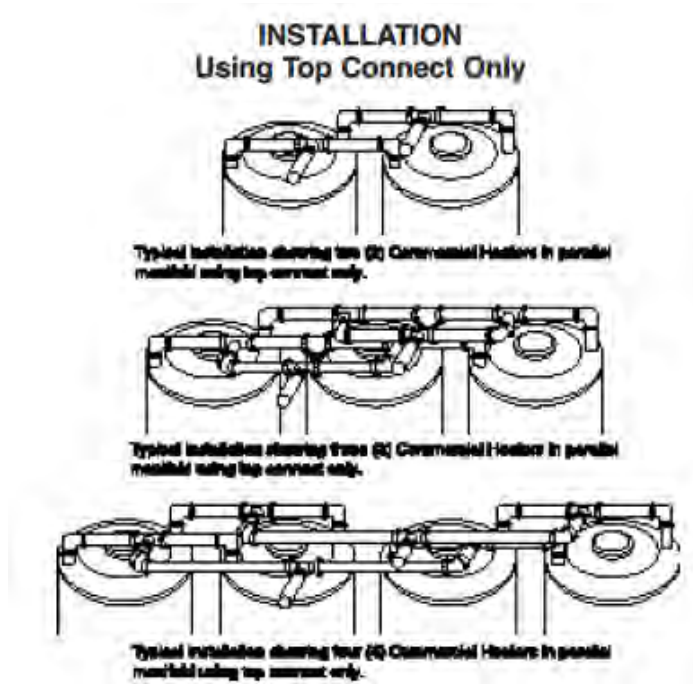

**FIGURE 7**

**WARNING !**

**HYDROGEN GAS**

Hydrogen gas can be produced in a hot water system that has not been used for a long period of time (generally two weeks or more). **HYDROGEN GAS IS EXTREMELY FLAMMABLE.** To prevent the possibility of injury under these conditions, we recommend the hot water faucet be opened for several minutes at the kitchen sink before you use any electrical appliance which is connected to the hot water system. Do not light a cigarette, cigar or pipe. Do not smoke. If hydrogen is present, there will probably be an unusual sound such as air escaping through the faucet as the water begins to flow. Remember, no smoking or open flame near the faucet at the time it is opened.

**TEMPERATURE AND PRESSURE RELIEF VALVE**

For protection against excessive pressures and/or temperatures, a temperature and pressure relief valve must be installed in the opening marked “temperature and pressure relief valve”. A design certified by a nationally recognized testing laboratory that maintains periodic inspection of production of listed equipment or materials, as meeting the requirements for Relief Valves and Automatic Gas Shut-off devices for Hot Water Supply Systems, ANSI Z21.22. Pressure rating of the valve must not exceed the working pressure shown on the rating plate of the water heater.

Relief piping must terminate 6 inches above a floor drain or external to the building. Do not thread, cap, or plug the end of this discharge line. Be certain that no contact is made with any live electrical part. Do not connect discharge line directly to drain. (Figure 5) To prevent bodily injury, hazard to life or damage to property, the relief valve must be allowed to discharge water in the event of excessive temperature or pressure developing in the water heater. The function of the temperature and pressure relief valve is to discharge water in large quantities should circumstances demand. If the discharge pipe is not directed to a drain as shown in Figure 5, or other suitable means, the water flow may cause property damage.

**The discharge line:**

- (1) Must not be smaller than the pipe size of the relief valve,
- (2) Must not be plugged or blocked,
- (3) Must be of material capable of withstanding 210°F without distortion,
- (4) Must be installed so as to allow complete drainage of both the temperature and pressure relief valve and discharge line,
- (5) Must terminate at an adequate drain (Figure 5)
- (6) Must not have any valve between the relief valve and the end of the discharge line.

Failure to install and maintain a new properly listed temperature and pressure relief valve will release the manufacturer from any claim which might result from excessive temperature or water pressure. **FIGURE 8**

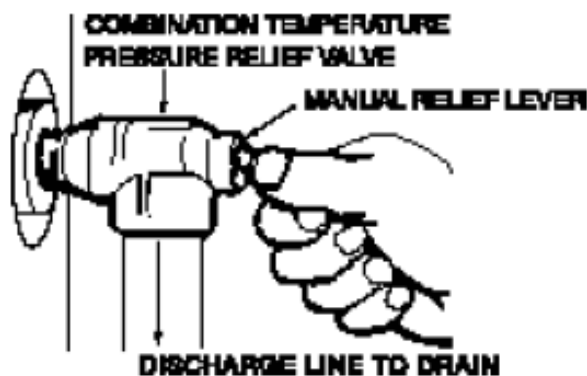

**WARNING !**

Do not attempt to operate this water heater with the cold water inlet valve closed. Manually operate the pressure-temperature relief valve at least once a year. To prevent water damage, discharge line must terminate at an adequate drain. Standing clear of the outlet (discharge water may be hot), lift and release the lever handle on the pressure-temperature relief valve to make the valve operate freely.

If the temperature and pressure relief valve on the appliance discharges periodically, this may be due to thermal expansion in a closed water supply system (see “Pressure Build-Up in Water System” - Page 1). Contact the water supplier or local plumbing inspector on how to correct this situation. Do not plug the temperature and pressure relief valve.

**ELECTRICAL**

120 VAC LESS THAN 5 AMPS

When installed, this appliance must be electrically grounded in accordance with local codes or in the absence of local codes, with the National Electrical Code, ANSI/NFPA NO. 70-Latest Edition and Canadian Electrical Code CSA #22.2. Electrical ON-OFF control must be located near heater in accordance with local code.

**CAUTION !**

Label all wires prior to disconnection when servicing controls. Wiring errors can cause improper and dangerous operation. Verify proper operation after servicing. Refer to Page 11, Figure 11, for wiring diagram D80-512AS model, and Refer to Page 10 Figure 10, for wiring diagram remains models.

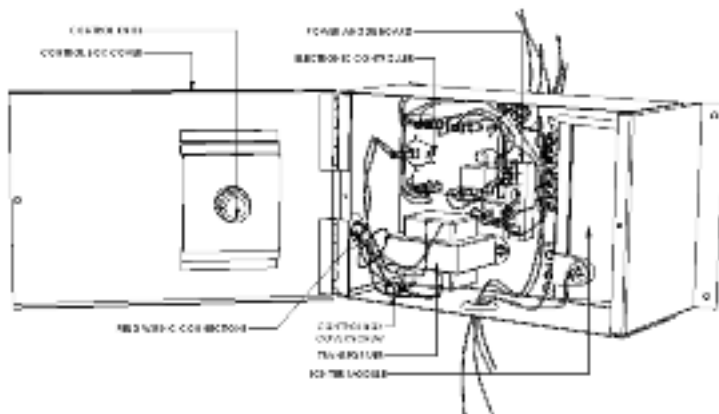

**FILLING HEATER WITH WATER**

1. Close the heater drain valve by turning the handle to the right (clockwise). The drain valve is on the lower front of heater.
2. Open the cold water supply valve to the heater.
3. To insure complete filling of the tank, allow air to exit by opening the nearest hot water faucet. Allow water to run until a constant flow is obtained. This will let air out of the heater and the piping.

**CAUTION !**

- Operating an empty or partially filled heater will result in damage to the tank.
4. Check all new water piping for leaks. Repair as needed.
5. Unit is ready to be started. Follow lighting instructions on Page 13.

**INSTALLATION CHECK LIST**

Before putting burner in operation

This is presented for ease of reference.

It is not comprehensive. All instructions and warnings must be read and adhered to.

**A. HEATER LOCATION**

- Close to area of vent.
- Indoors and protected from freezing temperatures.
- Proper clearance from combustible surfaces observed and heater not installed directly on carpeted floor.
- Sufficient fresh air supply for proper operation of heater.
- Air supply free of corrosive elements and flammable vapors.
- Provisions made to protect area from water damage.
- Sufficient room to service heater.

**B. WATER SUPPLY (See WATER PIPING)**

- Install cold water inlet valve (Figure 5)
- Heater completely filled with water.
- Water connection tight and free of leaks.

**C. RELIEF VALVE**

- Install a new Temperature and Pressure Relief Valve properly and discharge line run to open drain.
- Discharge line protected from freezing (Figure 5).

**D. GAS SUPPLY**

- Gas supply same as the type of gas listed on the rating plate.
- Gas line equipped with shut-off valve, union and dripleg (Figure 5).
- Approved pipe joint compound used.
- Soap and water solution used to check all connections and fittings for possible gas leaks.
- The installer to visually determine that the main burner flames are burning correctly without lifting, floating or flashing back and that the air shutters should be adjusted and locked to a position that results in correct burner flame pattern (see page 14) after to turn on water heater.

**E. VENTING**

- Draft diverter properly installed.
- Vent connector(s) securely fastened together with screws.
- Vent connector(s) at least 6" from combustible material.
- Check with spill test

**F. ELECTRICAL**

- 120 VAC supply.
- ON-OFF switch near heater.
- Cove on junction box.

**G. DAMPER**

- Damper in place on heater flue collector outlet.
- Damper plate has free movement.

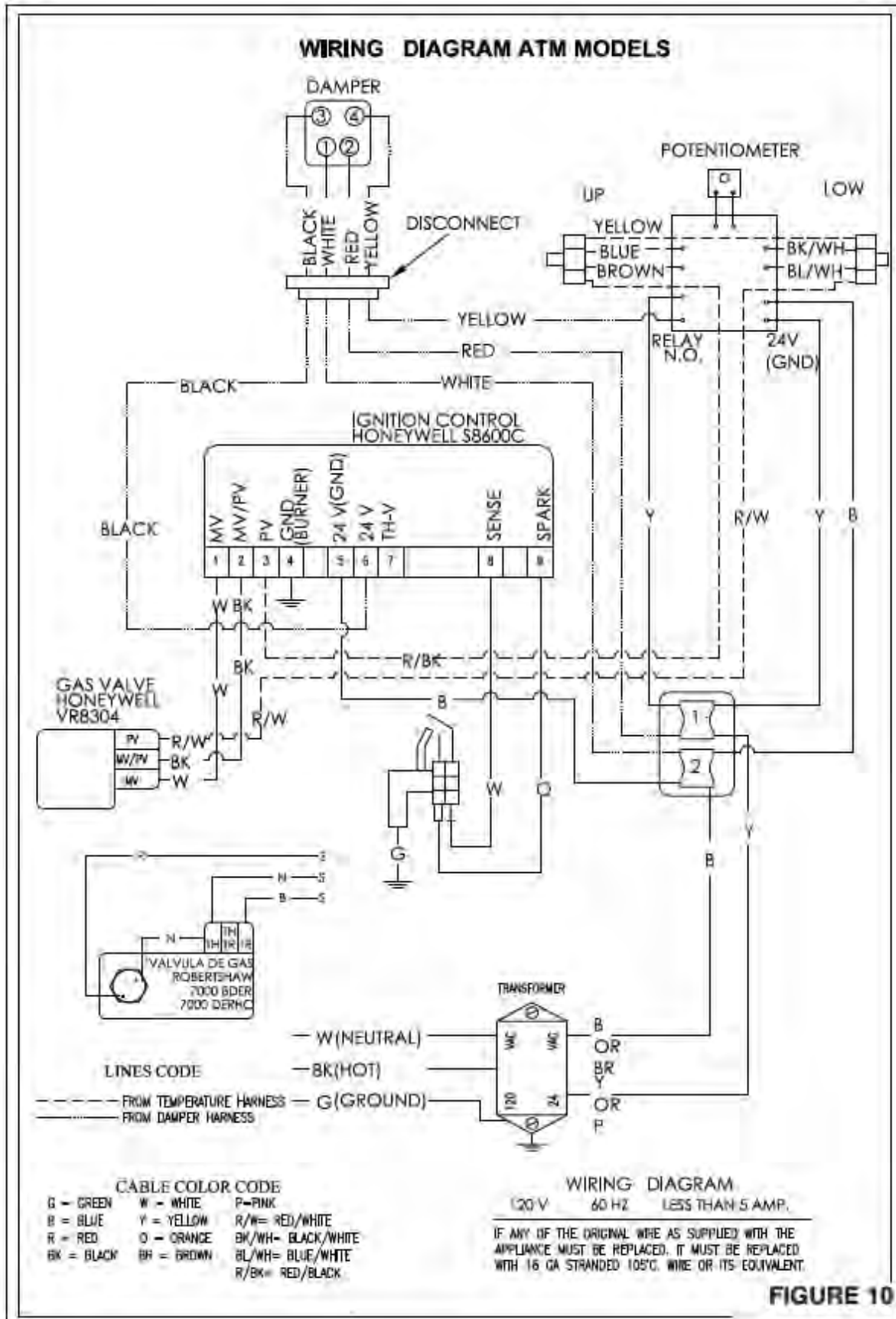

## DAMPER OPERATION SEQUENCE

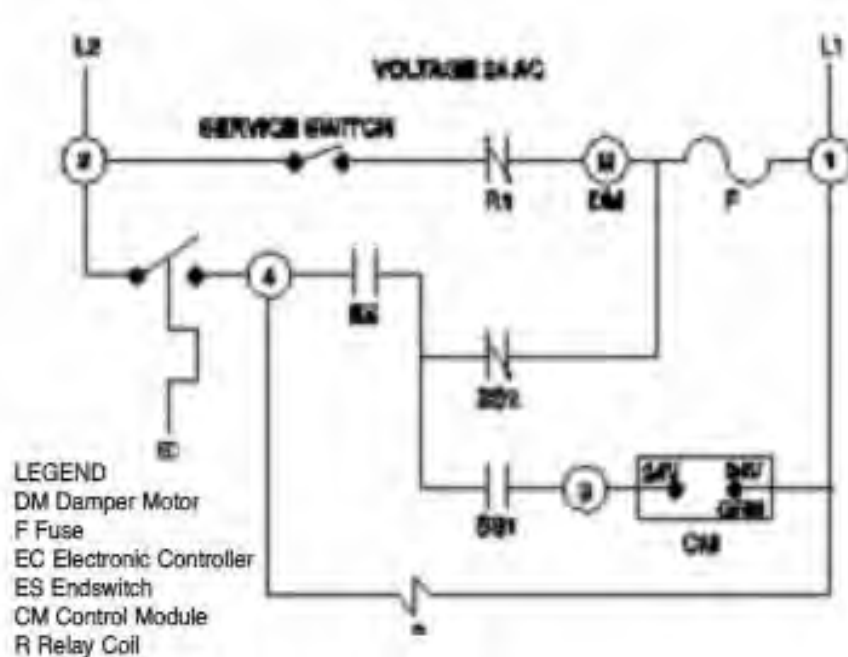

- LEGEND**  
 DM Damper Motor  
 F Fuse  
 EC Electronic Controller  
 ES Endswitch  
 CM Control Module  
 R Relay Coil  
 R1 N/C Relay Contact  
 R2 N/O Relay Contact  
 SS1 N/C Safety Switch Contact  
 SS2 N/O Safety Switch Contact

### OPERATION

In the standby condition (electronic controller satisfied) relay contacts R1 are closed and the motor (DM) is energized, which drives the damper vane closed. This opens the endswitch (ES) via a cam on the drive rod. When the damper is fully closed, the safety switch (N/C) contacts (SS1) are closed by the other drive rod cover. The torsion spring is wound up. Closure of the electronic controller (EC) energizes the relay coil (R) which opens the R1 contacts. The motor is de-energized and the spring drives the damper vane to the open position, the cam opens the safety switch contacts (SS2) and closes (SS1), and the endswitch contacts (ES). Closing of the endswitch energizes the control module. When the electronic controller is satisfied, it de-energizes the control module and the relay coil (R). Deenergizing the relay closes the R1 contacts which energizes the motor, driving the damper vane to the closed position.

In the event of an endswitch malfunction, where the contacts remain closed, the safety circuit detects this condition and disables the damper in the open position. This is accomplished when the electronic controller closes on the next call for heat, by a direct short through contacts, (SS2), (ES), the fuse, and the electronic controller. The short causes the fuse to blow, opening the motor circuit, which causes the damper to spring open and remain open. This will disable the damper in the open position and allow the appliance to remain operational.

### WARNING !

TO AVOID POSSIBLE INJURY, FIRE AND EXPLOSION, READ THESE PRECAUTIONS BEFORE ATTEMPTING TO LIGHT OR RELIGHT THE PILOT. Check the rating plate near the gas control valve electronic controller for correct gas. DO NOT USE THIS WATER HEATER WITH ANY GAS OTHER THAN THE ONE LISTED ON THE RATING PLATE (Figure 5). Failure to use the correct gas can cause problems which result in DEATH, SERIOUS BODILY INJURY, OR PROPERTY DAMAGE. If you have any questions or doubts consult your gas supplier or gas company.



## **NATURAL GAS MODELS**

### **IF YOU SMELL GAS:**

1. Open windows.
2. Get all people out of the building.
3. DO NOT light matches.
4. DO NOT touch electrical switches (on or off).
5. Extinguish any open flames.
6. Use an outside phone and immediately call the gas company and the fire department. Ask for instructions. Before hanging up, give your name and address.
7. DO NOT go back into the building. If help is coming, wait for it outside of the building.

## **L.P. (PROPANE, BOTTLED) GAS MODELS**

### **L.P. GAS IS HEAVIER THAN AIR**

Should there be a leak in the system, the gas will settle at FLOOR LEVEL.

Basements, crawl spaces, skirted areas under mobile homes (even when ventilated), closets and areas below ground level will serve as pockets for the accumulation of gas.

### **BEFORE LIGHTING, sniff at FLOOR LEVEL**

### **IF YOU SMELL GAS, FOLLOW THESE RULES:**

1. Open windows.
2. Get all people out of the building.
3. DO NOT light matches. Extinguish any open flame.
4. DO NOT touch electrical switches (on or off).
5. SHUT OFF GAS at L.P. tank outside of the building.
6. Use an outside phone and immediately call the gas company and the fire department. Ask for instructions. Before hanging up, give your name and address.
7. DO NOT go back into the building. If help is coming, wait for it outside of the building.

## **OUT OF FUEL**

When your L.P. tank runs out of fuel, turn off gas at all gas appliances including gas to pilots. After L.P. tank is refilled, all appliances must be re-lit according to the manufacturer's instructions, Page 13.

## **EXPOSURE TO WATER**

Do not use this appliance if any part has been under water. Immediately call a qualified service technician to inspect the appliance and to replace any part of the control system and any gas control which has been under water.

## **DANGER !**

Do not store or use any combustible materials or liquids, such as gasoline, paint thinners or other flammable vapors near any gas burning appliances. Vapors may be ignited by the pilot or main burner flames. No obstruction should be in the flow of combustion and ventilation air.

## **INSTRUCTIONS FOR CLEANING TANK**

A clean-out procedure is provided for periodic cleaning of the tank. Be sure that you have a new O ring on hand before proceeding. Part Number 10099.

1. Shut off gas supply to water heater.
2. Shut off electric supply.
3. Shut off water supply to water heater.
4. Open the nearest hot water faucet.
5. Attach hose to drain valve, and open drain valve so water can drain from water heater.

**WARNING !** This water can be hot.

6. Remove jacket clean-out cover from jacket (4 screws).
7. After the water heater has been drained, remove the hex head bolts and the plate will come loose. If necessary, tap lightly on the outside edge.
8. After tank has cooled, remove loose scale and lime deposits from inside tank, being careful not to break glass lining.

## TO RETURN WATER HEATER TO OPERATION

1. Replace O ring.
2. Re-install hand hole plate, with the hex head bolts, inserting all bolts in place before beginning final tightening. Tighten bolts, rotating on opposite sides, rather than in a continuous circular pattern.
3. Tighten water connection. Open cold water inlet valve to fill tank. When water flows in a steady even stream, close hot water faucet previously opened.
4. Turn on gas and/or electric supply to heater.
5. Using lighting instructions located on jacket of heater, put heater into operation.

## VACATION

When the heater is not to be used for extended periods of time (vacations, etc.) turn the temperature dial to its lowest setting. This will maintain the water at relatively low temperatures with minimum energy losses and prevent the tank from freezing during cold weather. When making adjustments to the electronic controller temperature setting, refer to the section on ELECTRONIC CONTROLLER. Also refer to Page 8 WARNING HYDRO-GEN GAS.

## COMBINATION SPACE HEATING / POTABLE WATER HEATING SYSTEM

When using this heater as a source of heat for a combination space heating/potable water heating system, be sure to follow manual(s) shipped with air handler system. Refer to figure 15 page 19.

Note the following warnings:

Toxic chemicals, such as those used for boiler treatment, shall NEVER be introduced into this system.

This unit may NEVER be connected to any existing heating system or component(s) previously used with a non-potable water heating appliance.

DO NOT use with piping that has been treated with chromates, boiler seal or other chemicals.

DO NOT add boiler treatment or any chemicals to any heat piping, since the piping contains potable water.

DO NOT use with ferrous piping. The system should be installed only with new piping that is suitable for potable water, such as copper or polybutylene. DO NOT use with PVC piping.

DO NOT use with any pumps, valves, or fittings that are not completely compatible with potable water piping.

DO NOT use valves that may cause excessive restriction to water flow.

USE FULL FLOW BALL OR GATE VALVES ONLY.

DO NOT tamper with the electronic controller, gas valve, igniter control or temperature and pressure relief valve. Tampering with any of these components is DANGEROUS and can result in property damage or severe injury. Tampering voids all warranties. Only qualified personnel should service these components.

DO NOT use 50/50 solder in potable water lines.

IF THE SPACE HEATING system requires water temperatures in excess of 140°F, a mixing valve or other means should be installed in the domestic (potable) hot water supply to limit the RISK OF SCALD DAMAGE.

SOME JURISDICTIONS may require a backflow preventer in the incoming cold water line to the water heater. In such cases, the temperature and pressure relief valve on the water heater may weep or relieve due to expansion of the heated water. A diaphragm-type expansion tank will normally eliminate this weeping condition. Please read and follow the manufacturer's instructions for installation of such tanks.

## VENTING SYSTEM INSPECTION

Check the draft hood relief opening (Figure 5) using a match flame after 15 minutes of operation. Pass the match flame around the relief opening of the draft hood. A steady flame drawn into the opening indicates proper draft. If the flame flutters or is blown out this would indicate spillage and corrective action must be made to the vent. (Figure 5)

A

At least every 3 months a visual inspection should be made of the venting system. You should look for:

Obstructions which could cause improper venting.

Damage or deterioration which could cause improper venting or leakage of combustion products.

## CONDENSATION

Whenever the heater is filled with cold water there will usually be a certain amount of condensation formed while the burner is ON. Moisture from the products of combustion condenses on the cooler tank surfaces to produce a "sizzling" or "frying" noise. During the winter months this condition will be more pronounced. Condensation is normal and should not be confused with a leaking tank. The water will be noted at different times of the year and in varying quantities.

THIS OPERATING INSTRUCTIONS ARE ONLY FOR D80-512 AS MODEL

## FOR YOUR SAFETY READ BEFORE LIGHTING

### WARNING

If you do not follow these instructions exactly, a fire or explosion may result causing property damage, personal injury or loss of life

- A. This appliance is equipped with an ignition device which automatically lights the pilot.  
Do not try to light the pilot by hand.
- B. BEFORE OPERATING smell all around the appliance area for gas. Be sure to smell next to the floor because some gas is heavier than air and will settle on the floor.
  - Do not try to light any appliance.
  - Do not touch any electric switch; do not use any phone in your building.
  - Immediately call your gas supplier from a neighbor's phone. Follow the gas supplier's instructions.
  - If you cannot reach your gas supplier, call the fire department.
- C. Use only your hand to push in or turn the gas control knob. Never use tools. If the knob will not push in or turn by hand, don't try to repair it, call a qualified service technician.  
Force or attempted repair may result in a fire or explosion.
- D. Do not use this appliance if any part has been under water. Immediately call a qualified service technician to inspect the appliance and to replace any part of the control system and any gas control which has been under water.

### OPERATING INSTRUCTIONS

1. STOP! Read the safety warnings above on this label.
2. Set the electronic controller to lowest setting.
3. Turn off all electrical power to the appliance.
4. This appliance is equipped with an ignition device which automatically lights the pilot.  
Do not try to light the pilot by hand.
5. Turn ON/OFF switch on the water heater to the "ON" position. See ON/OFF switch position figure.
6. Wait five (5) minutes to clear out any gas. If you then smell gas, STOP! Follow "B" in the safety information above on this label. If you don't smell gas, go to next step.
7. Set electronic controller to desired setting.
8. If ignition of the pilot and main burner is not established in approximately one minute, turn the electric supply to the heater "OFF" and then back "ON". This will reset the ignition cycle.
9. Repeat steps until ignition of the pilot and main burner is established.
10. If your appliance will not operate, follow the instructions "To turn Off gas to appliance" and call your service technician or gas supplier.
11. Check all pipe connections in the gas line and at the gas valve for gas leaks. Use a soap and water solution for this operation. NEVER USE AN OPEN FLAME FOR THIS PURPOSE.
12. Damper must be in open position when appliance main burner is operating.

### SWITCH POSITION

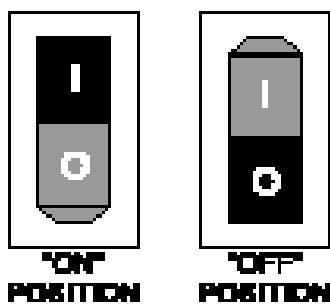

Note: Gas valve control #7010 does not have a manual "ON" "OFF" knob

### TO TURN OFF GAS TO APPLIANCE

1. Set the electronic controller to lowest setting.
2. Turn off all electrical power to the appliance if service is to be performed.
3. Turn the gas valve knob clockwise to "OFF" position.

## BEFORE PLACING THIS WATER HEATER IN OPERATION SEE “CONDENSATION” ON PAGE 12 FOR YOUR SAFETY READ BEFORE OPERATING

### WARNING !

If you do not follow these instructions exactly, a fire or explosion may result causing property damage, personal injury or loss of life.

A. This appliance is equipped with an ignition device which automatically lights the pilot.

Do not try to light the pilot by hand.

B. BEFORE OPERATING smell all around the appliance area for gas. Be sure to smell next to the floor because some gas is heavier than air and will settle on the floor.

### WHAT TO DO IF YOU SMELL GAS

- Do not try to light any appliance.
- Do not touch any electric switch; do not use any phone in your building.
- Immediately call your gas supplier from a neighbor's phone. Follow the gas supplier's instructions.
- If you cannot reach your gas supplier, call the fire department.

C. Use only your hand to push in or turn the gas valve knob. Never use tools. If the knob will not push in or turn by hand, don't try to repair it, call a qualified service technician.

Force or attempted repair may result in a fire or explosion.

D. Do not use this appliance if any part has been under water. Immediately call a qualified service technician to inspect the appliance and to replace any part of the control system and any gas control which has been under water.

### OPERATING INSTRUCTIONS

1. STOP! Read the safety warnings above on this label.
2. Set the electronic controller to lowest setting.
3. Turn off all electrical power to the appliance.
4. This appliance is equipped with an ignition device which automatically lights the pilot.  
Do not try to light the pilot by hand.
5. For models using gas valve with round control knob, turn gas valve knob clockwise to “OFF”.
- 5a. For models using gas valve with red control arm, depress red control arm and slide counterclockwise to “OFF”.
6. Wait five (5) minutes to clear out any gas. If you then smell gas, STOP! Follow “B” in the safety information above on this label. If you don't smell gas, go to next step.

### GAS VALVE CONTROL SHOWN IN “OFF” POSITION

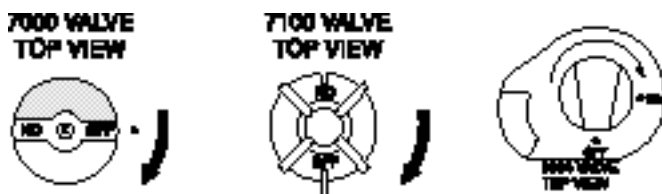

Note: Gas valve Robertshaw 7010 does not have a manual “on / off” knob

7. For models using gas valve with round control knob, turn gas valve knob counterclockwise to “ON”.

7a. For models using gas valve with red control arm, slide red control arm clockwise to “ON”.

8. Turn on all electric power to the appliance.

9. Set dial knob to desired setting.

10. If ignition of the pilot and main burner is not established in approximately one minute, turn the electrical power supply to the heater “OFF” and then back “ON”. This will reset the ignition cycle.

11. Repeat step 10 until ignition of the pilot and main burner is established.

12. If the appliance will not operate, follow the instructions “To Turn Off Gas To Appliance” and call your service technician or gas supplier.

13. Check all pipe connections in the gas line and at the gas valve for gas leaks. Use a soap and water solution for this operation. NEVER USE AN OPEN FLAME FOR THIS PURPOSE.

14. Damper must be in open position when appliance main burner is operating.

**TO TURN OFF GAS TO APPLIANCE**

1. Set the electronic controller to lowest setting.
2. Turn off all electrical power to the appliance if service is to be performed.
3. Turn the gas valve knob clockwise to "OFF" position.

**HI-TEMPERATURE LIMIT**

The electronic controller on this water heater is equipped with a high temperature limit switch (ECO). The ECO will shut off the gas supply to the burner and pilot in the event the water temperature exceeds 190 degrees F. Main burner operation can be reset by pressing the reset button on the ECO after the water temperature has returned to normal (see Fig. 12).

**WATER TEMPERATURE REGULATION**

The temperature of the water in the heater can be regulated by the setting of the temperature dial in the control box. To adjust the temperature setting, open cover and rotate dial to desired temperature setting (see Fig. 12)

**DANGER !**

Water temperatures over 125°F can cause severe burns instantly or death from scalds. Children, disabled, and elderly are at highest risk of being scalded. Feel water before bathing or showering. Temperature limiting valves are available, and should be installed when lower outlet temperatures are required.

**TEMPERATURE CONTROL**

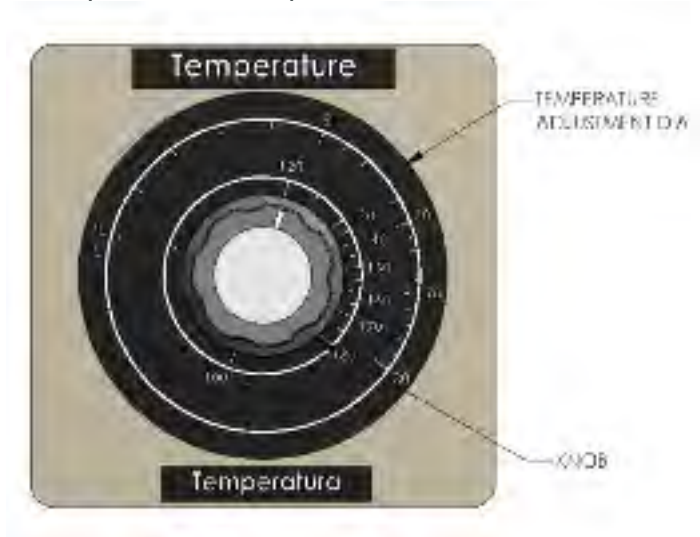

FIGURE 12

**GAS PRESSURE**

With the water heater in operation (main burner on), the maximum supply pressure must not exceed the specified value below, and the minimum supply and normal manifold gas pressures are as follows:

	<b>Supply Pressure</b> <b>MAX. MIN.</b>	<b>Manifold Pressure</b> <b>NORMAL</b>
<b>Natural Gas:</b>	<b>10.5" W.C. 5" W.C.</b>	<b>4" W.C.</b> (see rating plate)
<b>L.P. Gas: 13.0"</b>	<b>W.C. 11" W.C.</b>	<b>10" W.C.</b>

Refer to pressure noted on the label affixed to the front of the water heater. Consult your local gas company or gas supplier if correction is necessary.

**EMERGENCY SHUTDOWN**

**INSTRUCTIONS**

Should the water heater be subjected to flood, fire, or other unusual condition, turn off gas at manual shut-off valve and water inlet valve to heater. Refer to Figure 5. Do not place water heater in operation again until it has been thoroughly checked by qualified personnel.

**TAMPERING**

Tampering with the electronic controller, gas valve, igniter control, or temperature and pressure relief valve is **DANGEROUS** and voids all warranties. Only qualified personnel should service these components.

**WARNING** !

Should overheating occur or the gas fail to shut off, turn off the manual gas control valve to appliance, and call a qualified service person to check for the cause.

**MAINTENANCE****BURNER AND PILOT MAINTENANCE**

At least every 3 months, visually check main burner and pilot flames and compare with the sketch below. Observation of the gas flame should show the burner flame to be a soft blue with the suggestion of slight yellow tips. It is to be noted that the flame of a light color may not be a carbonizing flame.

Carbonizing flames are to be avoided and can be determined by wiping the tip of the combustion chamber when the flames is extinguished and the combustion chamber has cooled to determine if any carbon or soot has been deposited. If the burners are dirty or clogged with lint or soot, the burners can be cleaned with soap and water. If sooting re-occurs, refer to Common Complaints, Page 16.

At least every 3 months a visual inspection should be made of the venting system. You should look for:

- Obstructions which could cause improper venting.
- Damage or deterioration which could cause improper venting or leakage of combustion products.

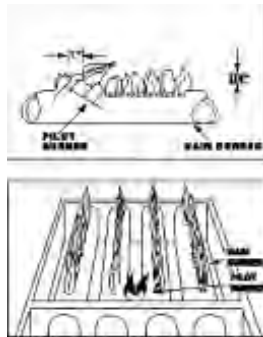

**PILOT AND MAIN BURNER FLAME PATTERN**

FIGURE 13

**Note:** Burner rods, running parallel with burner tubes, are not used on all models and are not shown on above drawings.

**WATER HEATER SOUNDS**

1. Possible noises due to expansion and contraction of some metal parts during periods of heat-up and cool-down do not represent harmful or dangerous conditions.
2. Sediment buildup in the tank bottom will create varying amounts of noise, and left in the tank, will cause premature tank failure.
3. Condensation causes sizzling and popping within the burner areas during heating and cooling periods and should be considered normal. See Condensation.

**DRAINING**

The water should be drained if being shut down during freezing temperatures. Also, periodic draining and cleaning of sediment from the tank may be necessary. See Page 12.

1. Turn gas valve knob clockwise to the OFF position.
2. Close the cold water inlet valve to the heater.
3. Open a nearby hot water faucet.
4. Open the heater drain valve.
5. If the heater is going to be shut down and drained for an extended period, the drain valve should be left open.

**WARNING** !

This water can be hot.

**CAUTION** !

This water heater should not be used to heat a spa or hot tub

This water heater is not intended or suited for use with a hot tub or spa and may not be used for this purpose

**SERVICE MUST BE PERFORMED BY A QUALIFIED INSTALLER, SERVICE AGENCY OR GAS SUPPLIER**

Following is a list of the most common complaints related to the use of water heaters. Many complaints are due to items not directly related to the water heater. Do not attempt to service the water heater or perform other recommendations on this list unless you are trained and qualified to do so.

**COMMON COMPLAINTS**

CONDITION	CAUSE	REMEDY
Burner will not ignite	No gas	Check with utility
	Dirt in gas line	Notify utility-install dirt trap in gas lines
	Pilot line clogged	Clean-check for source of trouble & correct
	Main burner line clogged	Clean-check for source of trouble & correct
	Defective electronic controller	Replace with new electronic controller
	Electronic controller set too low	Turn temperature dial to desired temperature
	Heater installed in confined area	Provide ventilation by use of louvers in wall or duct
	Defective gas valve	Replace with new gas valve
Burner flame floats/lifts off ports	High gas pressure	Check with utility
	Orifice too large	Replace with correct orifice
	Flue clogged	Clean-check for source of trouble & correct
	Heater installed in confined area	Provide ventilation by use of louvers in wall or duct
	Cold drafts	Check source & correct
Burner flame yellow/lazy	Insufficient secondary air	Provide ventilation to heater
	Low gas pressure	Check with utility
	Flue clogged	Clean-check for source of trouble & correct
	Main burner line clogged	Clean-check for source of trouble & correct
	Heater installed in confined area	Provide ventilation by use of louvers in wall or duct
Burner flame too high	Insufficient secondary air	Provide ventilation to heater
	Orifice too large	Replace with correct orifice

Flame burns at orifice	Low gas pressure	Check with utility
	Defective electronic controller	Replace with new electronic controller
Pilot will not remain lit	Low gas pressure	Check with utility
	Defective electronic controller	Replace with new electronic controller
	No gas	Check with utility
	Dirt in gas lines	Notify utility-install dirt trap in gas lines
	Pilot line clogged	Clean-check for source of trouble & correct
High operating costs	Improper calibration	Replace control valve
	Electronic controller set too high	Turn temperature knob to desired temperature
	Sediment or lime in tank	Clean out sediment; Refer to Page 12
	Heater too small for job	Install adequate heater
	Leaking faucets	Repair faucets
	Gas leaks	Check with utility-repair at once
	Wasted hot water	Advise customer
	Long runs of exposed piping	Insulate
	Hot water piping in outside wall	Insulate
Insufficient hot water	Low gas pressure	Check with utility
	Orifice too small	Replace with correct orifice
	Electronic controller set too low	Turn temperature dial to desired temperature
	Heater too small for job	Install adequate heater
	Leaking faucets	Repair faucets
	Wasted hot water	Advise customer
	Long runs of exposed piping	Insulate
	Hot water piping in outside wall	Insulate
Slow water recovery	Insufficient secondary air	Provide ventilation to heater
	Low gas pressure	Check with utility
	Orifice too small	Replace with correct orifice
	Electronic controller set too low	Turn temperature dial to desired temperature
	Sediment or lime in tank	Clean out sediment; Refer to Page 12
	Heater too small for job	Install adequate heater
	Wasted hot water	Advise customer
Drip from relief valve	Excessive water pressure	Use pressure reducing valve
Electronic Controller fails to close	Defective electronic controller	Replace with new electronic controller
Condensation		See Page 12
Combustion Odors	Insufficient secondary air Flue clogged	Provide ventilation to heater Clean-check for source of trouble & correct
Smoking and carbon formation	Insufficient secondary air	Provide ventilation to heater
	Low gas pressure	Check with utility
	Orifice too large	Replace with correct orifice
	Flue clogged	Clean-check for source of trouble & correct
	Heater installed in confined area	Provide ventilation by use of louvers in wall or duct



Pilot flame too small	Low gas pressure	Flue clogged
	Pilot line clogged	Clean-check for source of trouble & correct
	Pilot line not clogged	Adjust pilot
Pilot flame too large	Pilot line not clogged	Adjust pilot

**REPLACEMENT PARTS LIST**

PARTS REPLACEMENT MUST BE PERFORMED BY A QUALIFIED INSTALLER, SERVICE AGENCY OR GAS SUPPLIER

The following parts may be ordered through your plumber, a local plumbing supply company, or direct from the factory. Parts will be shipped at prevailing prices and will be billed accordingly. Refer to warranty for company address.

**IMPORTANT:** When ordering replacement parts, provide model number, serial number, type of gas, item number (from the following list), part description, voltage and wattage (when applicable).

It is imperative that replacement of main burner orifices, pilot burner and gas valve be ordered for the gas type. Natural gas valves will be marked with a 4.0" w.c. manifold pressure setting (see rating plate). L.P. Gas valves will be marked with a 10.0" w.c. setting.

**Part No. Description**

- 1 Drafthood
- 2 Dip tube
- 3 Flue baffle
- 4 Hand hole tank cover
- 5 Drain valve
- 6 Hand hole cover jacket
- 6a Hand hole cover gasket
- 7 Heat shield
- 8 Main burner tube(s) quantity and length vary depending on model
- 8a Burner rods, sets of 2 per burner (some models)
- 9 Burner tray
- 10 Pilot burner assembly
- 11 Pilot supply tube
- 12 Main burner manifold
- 13 Gas valve (emergency shut-off device)
- 14 Main burner orifice
- 15 Bracket potentiometer (spark ignition models)
- 16 Transformer (spark ignition models)
- 17 Ignition control (spark ignition models)
- 18 Terminal block (spark ignition models)
- 19 Control box (spark ignition models)
- 20 Electronic controller (emergency shut-off device)
- 21 Capillary tube cover
- 22 Damper harness (flue damper models only)
- 23 Flue damper (flue damper models only)
- 24 Anode rod
- 25 Tank leg thermal break (required on all combustible floor installations)
- 26 Manual shut-off valve if applicable (emergency shut-off device)
- 27 Rod clips (4 per burner) - some models
- 28 Rod spring (2 per burner) - some models
- 29 Damper reducer (some models)
- 30 Sensor
- 31 Knob (spark ignition models)
- 32 Potentiometer (spark ignition models)

**REPLACEMENT PARTS ILLUSTRATION**

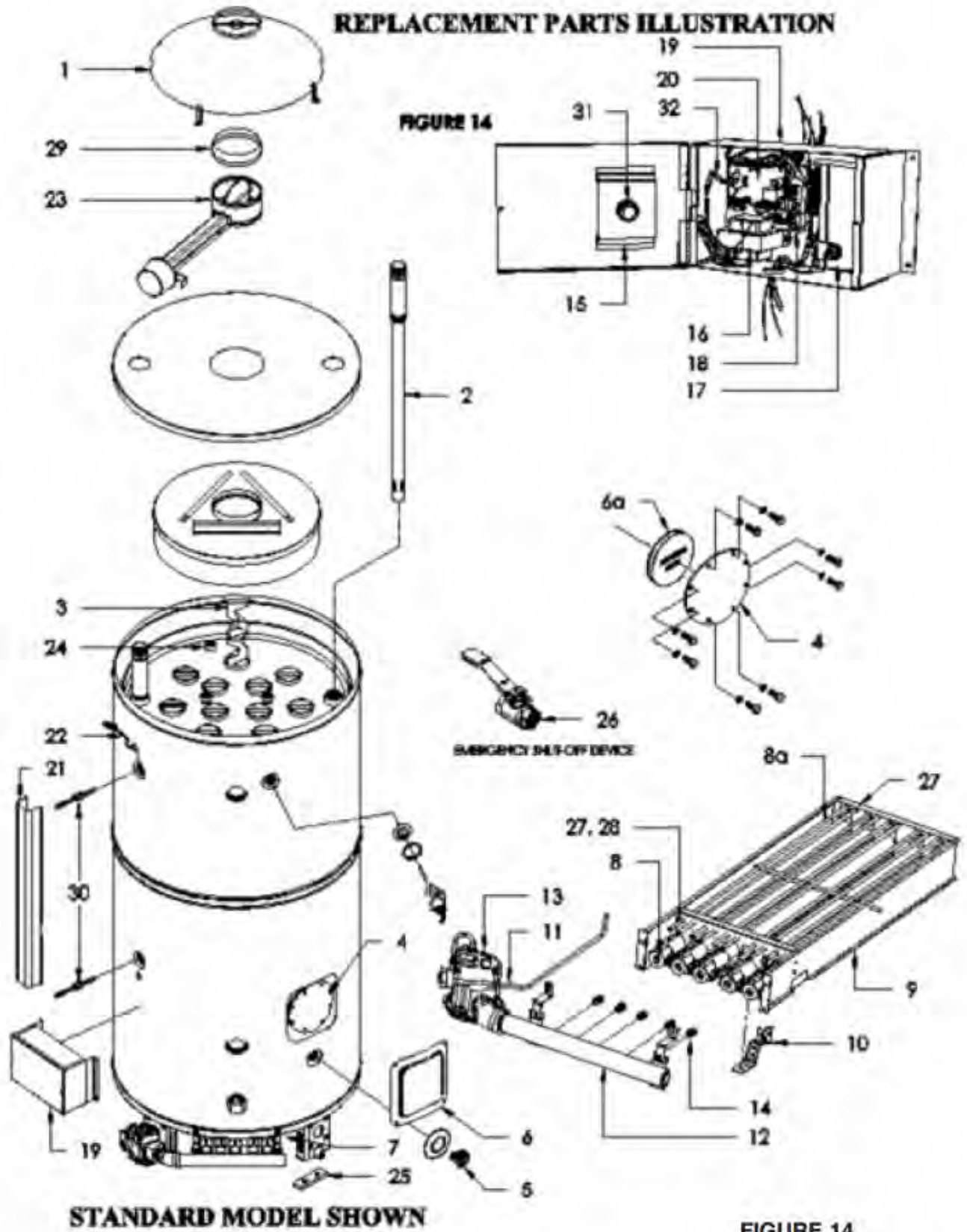

**COMBINATION SPACE HEATING / POTABLE  
WATER HEATING SYSTEM**

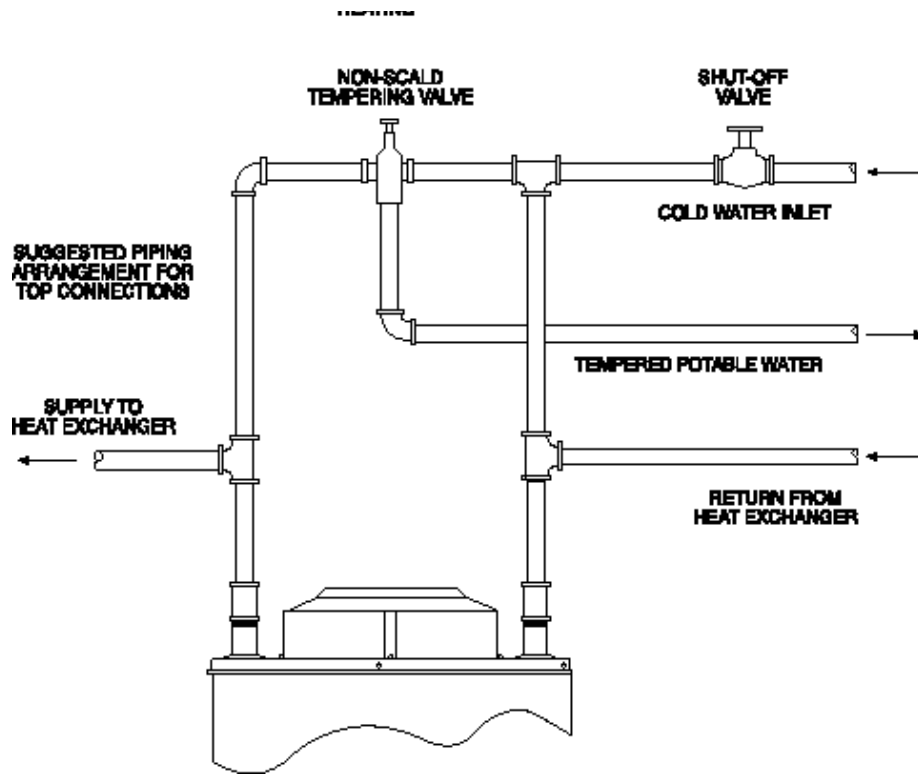

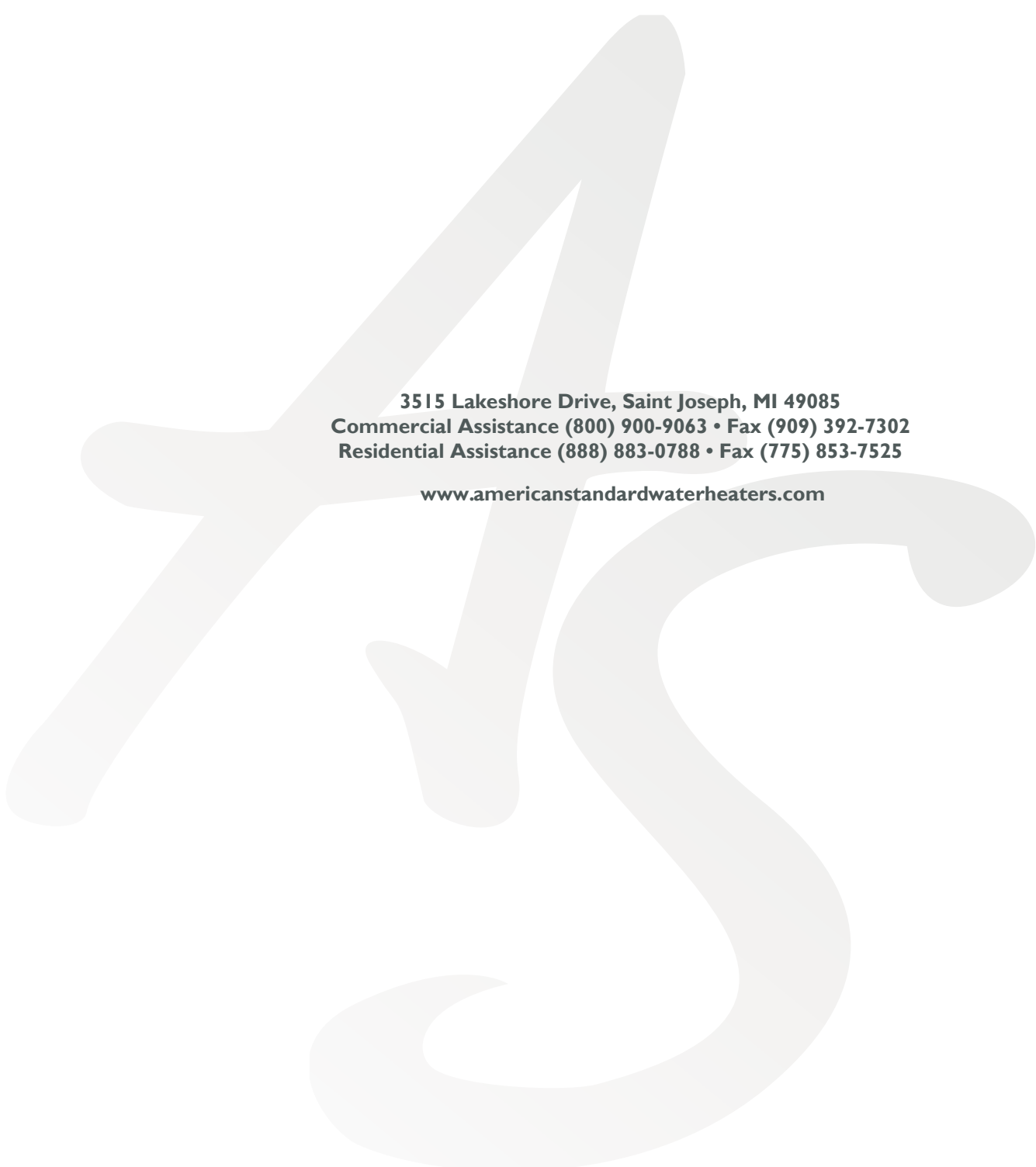

**3515 Lakeshore Drive, Saint Joseph, MI 49085**  
**Commercial Assistance (800) 900-9063 • Fax (909) 392-7302**  
**Residential Assistance (888) 883-0788 • Fax (775) 853-7525**

[www.americanstandardwaterheaters.com](http://www.americanstandardwaterheaters.com)