

American Standard®

WATER HEATERS



TANKLESS CONDENSING WATER HEATER

USER'S INFORMATION MANUAL

APPLICABLE MODEL:
TCWH180S-AS
TCWH199S-AS



NOTICE: American Standard Water Heaters reserves the right to make product changes or updates without notice and will not be held liable for typographical errors in literature.

NOTE TO CONSUMER: PLEASE KEEP ALL INSTRUCTIONS FOR FUTURE REFERENCE.

The surfaces of these products contacted by consumable water contain less than 0.25% lead by weight, as required by the Safe Drinking Water Act, Section 1417



WARNING

IF THE INFORMATION IN THIS MANUAL IS NOT FOLLOWED EXACTLY, A FIRE OR EXPLOSION MAY RESULT, CAUSING PROPERTY DAMAGE, PERSONAL INJURY OR DEATH. DO NOT STORE GASOLINE OR OTHER FLAMMABLE VAPORS AND LIQUIDS IN THE VICINITY OF THIS OR ANY OTHER WATER HEATER.

WHAT TO DO IF YOU SMELL GAS

Do not try to light any water heater.

Do not touch any electrical switch.

Do not use any phone in your building.

Immediately call your gas supplier from a neighbor's phone. Follow the gas supplier's instructions.

If you cannot reach your gas supplier, call the fire department. Installation and service must be provided by a qualified installer, service agency, or the gas supplier.

FOR YOUR SAFETY READ BEFORE OPERATING

WARNING !



If you do not follow these instructions exactly, a fire or explosion may result causing property damage, personal injury or loss of life.

- A. This appliance does not have a pilot. It is equipped with an ignition device which automatically lights the burner. Do not try to light the burner by hand.
- B. BEFORE OPERATING check and smell for gas everywhere around the appliance. Be certain to smell next to the floor as some gas is heavier than air and may settle on the floor.

WHAT TO DO IF YOU SMELL GAS

- Do not touch any electric switch; do not use any phone in your building.
 - Do not try to light any appliance.
 - Immediately call your gas supplier from a neighbor's phone. Follow the gas supplier's instructions.
 - If you cannot reach your gas supplier, call the Fire Department.
- C. Use only your hand to push-in or turn the gas control knob. Never use tools. If the knob will not push-in or turn by hand, do not attempt to repair it, call a qualified technician. Forced or attempted repair may result in a fire or explosion.
- D. Do not use this appliance if any part has been submerged under water. Immediately call a qualified technician to inspect the appliance and replace those parts of the control system and gas controls that were under water.

OPERATING INSTRUCTIONS

1. STOP! Read the safety information above on this label.
2. Set the thermostat to lowest setting. (**Never use Water Heater unless it is completely filled with water**).
3. Turn OFF electrical power supply to the Water Heater.
4. Don't try to light the burner by hand.
5. Turn gas shut-off valve clockwise  to "OFF" position. Do not force.
6. Wait five (5) minutes for any gas to clear-out. If you then smell gas, STOP! Follow step "B" above on this label. If you don't smell gas, go to the next step.
7. Turn manual gas shut-off valve counterclockwise  to "ON" position.
8. Turn ON electrical power to the appliance.
9. Wait until default temperature (125°F) is displayed. Set desired water temperature. Turn on hot water faucet.
10. Set thermostat to desired setting.
11. If the appliance will not operate, follow the instructions "To Turn Off Gas To Appliance" and call your service technician or gas supplier.

TO TURN-OFF GAS TO APPLIANCE

1. Set the thermostat to lowest setting.
2. Turn-off all electric power to the appliance if service is to be performed.
3. Turn manual gas shutoff valve to "OFF".

SPECIAL ATTENTION BOXES

The following terms are used throughout this manual to define and draw the attention of readers to the presence of hazards of various risk levels, or to important product information.

DANGER !

DANGER indicates an imminently hazardous situation which, if not avoided, may result in serious injury or death.

CAUTION !

CAUTION indicates a potentially hazardous situation which, if not avoided, may result in minor or moderate injury.

CAUTION

CAUTION used without the safety alert symbol indicates a potentially hazardous situation which, if not avoided, may result in property damage.

NOTE:

Indicates attention is required and details important information to a particular procedure.

CONTENTS

DANGER !

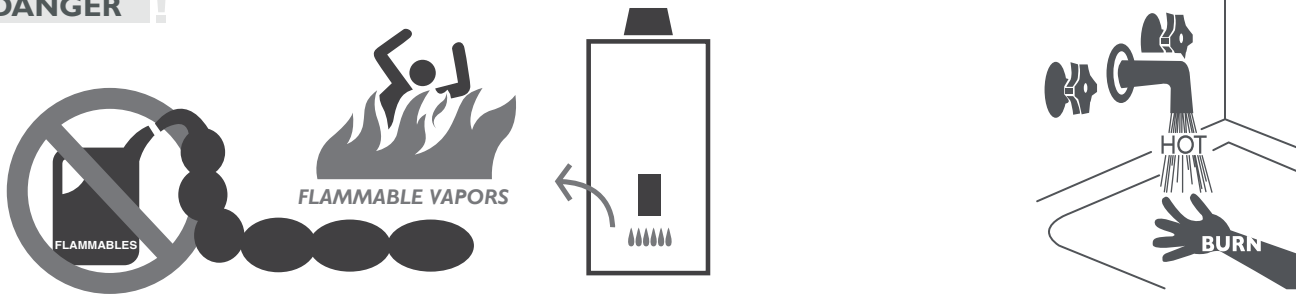

Vapors from flammable liquids will explode and ignite fire causing severe burns or death.

Do not store or use flammable products such as adhesives, gasoline or solvents near or in the same location of water heater.

Keep flammable products:

1. far away from heater,
2. in approved containers,
3. tightly closed and
4. out of children's reach.

Water heater uses a main burner.

The burner flame:

1. is on all the times and
2. will ignite flammable vapors.

Vapors:

1. cannot be seen,
2. are heavier than air,
3. travel a long distance across floors and
4. can be carried to and from other rooms.

Installation:

Do not install water heater where flammable products will be stored or used such as a basements, garages, storage areas or utility rooms unless the main burner is at least 18" above the floor. This will reduce, but not eliminate, the risk of vapors being ignited by the main burner flame. Read and follow water heater instructions and warnings. If owners manual is missing, contact the retailer or manufacturer.

DANGER !

Water temperatures over 125° F can cause severe burns instantly or death from scalds. Children, disabled and the elderly are at the highest risk of being scalded. See instruction manual before setting water heater temperature.

Feel water before bathing or showering.

Temperature limiting valves are available, see manual.

TABLE OF CONTENTS

Part 1 Product and Safety Information	4
A. Before operation	5
B. During operation	6
C. Troubleshooting and general cautionary statements	7
Part 2 Maintenance	9
A. Service technician	9
B. Owner maintenance	9
Part 3 Maintenance Procedures	10
A. Daily maintenance	10
B. Monthly maintenance	11
C. 6 Months maintenance	12
B. Annual maintenance	13
Part 4 Troubleshooting	14
Maintenance Notes	14

PART I PRODUCT AND SAFETY INFORMATION

WARNING !

USER – Have this water heater serviced/inspected by a qualified service technician annually.

FAILURE TO ADHERE TO THE GUIDELINES IN THIS MANUAL CAN RESULT IN SUBSTANTIAL PROPERTY DAMAGE, SEVERE PERSONAL INJURY, OR DEATH.

WARNING !

OPERATING INSTRUCTIONS

1. STOP! DO NOT use this water heater unless it is completely filled with water.
2. Ensure electrical power to the water heater is turned OFF.
3. This water heater is equipped with an ignition device which automatically lights the burner. DO NOT attempt to light the burner by hand.
4. Turn the gas shut-off valve clockwise to the “OFF” position. Do not force.
5. Wait five (5) minutes to clear out any gas. If you smell gas, STOP! Follow the information on page 2, this manual. If you don't smell gas, go to the next step.
6. Turn manual gas shut-off valve to the “ON” position.
7. Turn ON electrical power to the water heater.
8. Wait until default temperature (125°F) is displayed. Set desired water temperature.
9. If the water heater will not operate, follow the instructions on page 2 to turn off the gas to the water heater. Then call your service technician or gas supplier.

TO TURN OFF GAS TO THE WATER HEATER

1. Set the thermostat to the lowest setting.
2. Turn off all electrical power to the water heater.
3. Turn manual gas shutoff valve to “OFF”.

WARNING !

- Proper care of this water heater is the user's / owner's responsibility. The user / owner should carefully read and understand the operating information in this manual before operating this water heater.
- It is the user / owner's responsibility to know the location of the gas shut-off valve and how to operate it. Immediately close the gas shut-off valve if the water heater is subjected to fire, overheating, flood, physical damage, or any other damaging condition that might affect the operation of the unit. Have the water heater checked by a qualified technician before resuming operation.
- DO NOT use this water heater if ANY part has been under water. Immediately call a qualified technician to inspect the water heater and replace any part of the control system or gas control which has been under water.
- DO NOT power up the water heater unless the gas and water supply valves are fully opened. Make sure the fresh air intake pipe and exhaust vents are open and functional.
- DO NOT attempt to install, repair, or service this water heater. Contact a qualified technician if the water heater needs repair or maintenance. Ask your gas supplier for a list of qualified service providers.

- DO NOT use spray paint, hair spray, or any other flammable sprays near the water heater or near the exterior fresh air intake pipe termination.
- DO NOT place any items in or around the exterior exhaust vent termination and/or fresh air intake pipe that could restrict or block the flow in or out of the vent system.
- All safety devices must be tested after the water heater is installed. Always verify proper water heater operation after servicing.
- The gas ignition system components must be protected from water (dripping, spraying, rain, etc.) during water heater operation and service (circulator replacement, condensate trap, control replacement, etc.)
- The E80 code will display when there is no water in the water heater. Ensure the water heater is full of water. Then manually reset the water heater to resume operation.
- This water heater features a factory installed overheating prevention device. This limit provides water heater shut down in the event that the water heater water temperature exceeds the set point of the limit control. Certain local codes require additional water temperature limiting devices.
- Failure to follow these warnings could result in property damage, personal injury, or death.

A. BEFORE OPERATION

1. Check the Gas Type (NG/LP)

When operating the water heater for the first time, ensure the connected gas type matches that of the gas type of the water heater. Check whether the gas supplied is NG or LP. The water heater gas type is indicated on the rating plate on the side of the water heater.

WARNING !

Attempting to operate this water heater on a gas supply other than specified on the rating plate will result in improper water heater operation, and could result in property damage, personal injury, or death.

2. Check the Power (120V 60Hz).

Ensure the water heater is connected to a properly rated power supply.

3. Check the Cold Water Inlet Valve.

Ensure the cold water inlet valve is open when operating the water heater. The water heater will not operate if there is insufficient water supply.

4. Check the Gas Valve.

Ensure the manual shut-off gas valve is open. The water heater will not operate unless it is supplied with gas.

5. Check the area around the water heater. Remove any combustible or flammable materials from the area around the water heater and do not hang wet laundry from the exhaust vent pipe.

DANGER !

Do not operate the water heater if its combustion air intake is located in or near one of the areas or in the vicinity of products listed in Table 1. These areas will always contain hazardous contaminants that can form strong acids while passing through the burner and vent system. These acids will corrode the water heater's heat exchanger, burner components and vent system, resulting in flue gas spillage and/or water leakage, possible substantial property damage, severe personal injury, or death. If the water heater combustion air intake is located in any area likely to cause or contain contamination, or if products which would contaminate the air cannot be removed, the intake must be re-piped and terminated to another location.

DO NOT re-pipe ventilation system on your own. Call a qualified service provider for assistance.

Products to Avoid	Areas likely to have contaminants
Spray cans containing fluorocarbons	Dry cleaning/laundry areas and establishments
Permanent wave solution	Swimming pools
Chlorinated waxes/cleaners	Metal fabrication plants
Chlorine-based swimming pool chemicals	Beauty shops
Calcium chloride used for thawing	Refrigeration repair shops
Sodium chloride used for water softening	Photo processing plants
Refrigerant leaks	Auto body shops
Paint or varnish removers	Plastic manufacturing plants
Hydrochloric or Muriatic acid	Furniture refinishing areas and establishments
Cements and glues	New building construction
Antistatic fabric softeners used in clothes dryers	Remodeling areas
Chlorine-type bleaches, laundry detergents, and cleaning solvents	Garages and workshops
Adhesives used to fasten building products	New building construction / Remodeling areas

TABLE I
B. DURING OPERATION

1. Check for Gas Leaks

Frequently check the gas pipe and connections for leaks with a soapy solution. If air bubbles appear during the test, gas is leaking out. Close the gas supply valve and call your gas supplier for inspection.

WARNING !

After any repair of the gas pipeline or replacement of the gas regulator, call a qualified service technician to observe the installation and replacement before restoring power to the water heater. Failure to do so could result in a fire or explosion, substantial property damage, severe personal injury, or death.

2. Check for Proper Ventilation

Ensure there is sufficient ventilation while operating the water heater. Improper ventilation could result in premature water heater failure. Such failures ARE NOT covered by water heater warranty.

WARNING !

Breathing Hazard - Carbon Monoxide gas

- Do not operate water heater if flood damaged.
- Install vent system in accordance with local codes and manufactures installation instructions.
- Do not obstruct heater air intake or exhaust. Support all vent piping per manufacturers installation instructions.
- Do not place chemical vapor emitting products near unit.
- According to NFPA 720, carbon monoxide detectors should be installed outside each sleeping areas.
- Never operate the water heater unless it is vented to the outdoors.
- Analyze the entire vent system to make sure that condensate will not become trapped in a section of vent pipe and therefore reduce the open cross sectional area of the vent.



WARNING !

Exhaust gas entering the living space can cause carbon monoxide poisoning.

If exhaust gas should leak into the living space:

- Shut down the water heater.
- Close the gas valve.
- Open windows for ventilation.

Immediately call a qualified service technician to inspect the water heater and exhaust vent pipe. Any damages to the exhaust vent pipe should be repaired immediately. Failure to do so could result in substantial property damage, severe personal injury, or death.

3. Burn Warning

Take caution when inspecting the water heater, exhaust vent, and/or water pipes. These components can get extremely hot during water heater operation.

4. Combustible and Flammable Material Warning

Do not store combustible or flammable materials in the vicinity of this water heater. Do not hang clothes from the exhaust pipe.

WARNING !

Storing flammable or combustible materials near this water heater could result in a fire or explosion, substantial property damage, severe personal injury, or death.

5. Check for Water Leaks

- Do not attempt to clean the heating system. Call a qualified service technician for service.
- If you notice any leaks, immediately call a qualified service technician. Leaks in water heater or piping must be repaired at once.

C. TROUBLESHOOTING AND GENERAL CAUTIONARY STATEMENTS

DO NOT use this water heater for any purpose other than those specifically described by American Standard Water Heaters (to provide domestic hot water). Using this water heater for unapproved purposes WILL VOID the warranty, and could result in property damage, serious personal injury, or death.

WARNING !

DO NOT wipe the water heater or control panel with a wet cloth. Doing so may result in an electric shock, substantial property damage, premature water heater failure, severe personal injury, or death.

WARNING !

DO NOT shut off the water heater for long periods of time during potentially freezing conditions. This water heater has a freeze protection function. The ceramic heater installed inside of the heater's heat exchanger is designed to protect the water heater from freezing.

Ensure the exposed water pipes are thermally insulated to prevent damage due to freezing conditions. If the water heater is not to be used for an extended period of time during freezing conditions, consider shutting down the system and draining it of water. Shut off the gas and cold water supply valves.

If the water pipes should freeze, thaw the pipes with a hair dryer or other electric heating device. If this does not work, call a qualified service technician.

Failure to provide freeze protection could result in substantial property damage due to bursting pipes, personal injury, or death.

WARNING !

DO NOT attempt to disassemble this water heater. Doing so could result in improper water heater operation or premature water heater failure, substantial property damage, and/or severe personal injury or death due to electric shock, fire, or explosion. If repairs are required, contact a qualified service technician.

CAUTION !

DO NOT touch the exhaust vent or hot water pipes during water heater operation. Doing so could result in substantial personal injury.

DANGER !

Be careful when opening a hot water faucet or draining water from the water heater. Water temperature over 125°F can instantly cause severe burns, or death, from scalds. Children, disabled, and elderly are at the highest risk of being scalded. See instruction manual before setting temperature at water heater. Feel water before bathing or showering!

PART 2 MAINTENANCE

A. SERVICE TECHNICIAN

The following maintenance should be performed by a qualified service technician annually:

General

- Attend to any reported problems.
- Inspect the interior of the water heater cabinet; clean and vacuum if necessary.
- Clean the condensate trap and fill with fresh water.
- If applicable, check the condensate neutralizer and ensure it is full of condensate neutralizing marble chips.
- Check for leaks: Water, gas, flue and condensate.
- Verify exhaust vent and intake piping are in good condition and sealed tight.
- Check exhaust vent and intake pipe bracing. Ensure bracing is undamaged and in good condition.
- Check water heater water pressure, piping and expansion tank.
- Check control settings.
- Check ignition electrode. Sand off any white oxide. Clean and reposition.
- Check ignition and ground wiring.
- Check all control wiring and connections.
- Check burner flame pattern (stable and uniform).

Additional Items if Combustion or Performance is Poor

- Clean heat exchanger and flue ways.
- Remove burner assembly and clean burner head using compressed air only.

Once the maintenance items are completed, the service technician should review service with the owner.

B. OWNER MAINTENANCE

Periodically

- Check area around the water heater.
- Check and remove any blockage from the outdoor exhaust vent and intake pipe terminations. DO NOT perform this maintenance if exhaust vent and intake pipe terminations are in difficult to reach locations.
- Check the temperature/pressure gauge.

Monthly

- Check exhaust vent and intake piping.
- Check exhaust vent and intake pipe bracing. Ensure bracing is undamaged and in good condition.
- Check the pressure relief valve.
- Check the condensate drain system.
- If applicable, check the condensate neutralizer and ensure it is full of condensate neutralizing marble chips.

Every 6 Months

Check water heater piping and gas supply piping for corrosion or signs of potential leakage.

PART 3 MAINTENANCE PROCEDURES

DANGER !

The water heater must be inspected and serviced annually, preferably at the start of the heating season, by a qualified service technician. In addition, the maintenance and care of the water heater as outlined in this manual must be performed by the user/owner to assure maximum efficiency and reliability. Follow the maintenance procedures given throughout this manual. Failure to perform the service and maintenance or follow the directions in this manual could damage the water heater or system components, resulting in substantial property damage, severe personal injury, or death.

A. DAILY MAINTENANCE

Check the Surrounding Area

DANGER !

To prevent the potential of substantial property damage, severe personal injury, or death, eliminate all the materials listed in Table 1 from the area surrounding the water heater and the vicinity of the combustion air intake. If contaminates are found:

- **Remove products immediately from area.**
- **If contaminates have been there for an extended period, call a qualified service technician to inspect the water heater for possible damage from acid corrosion.**

If products cannot be removed, immediately call a qualified service technician to re-pipe the combustion air intake piping away from the contaminated areas.

Combustible/Flammable Materials

Do not store combustible materials, gasoline, or other flammable vapors or liquids near the water heater. If found, remove these materials immediately.

Air Contaminates

If allowed to contaminate combustion air, products containing chlorine or fluorine will produce acidic condensate that will cause significant damage to the water heater. Read the list of potential contaminates and areas likely to have these contaminates in Table 1, Part 2. If any of these contaminates are in the room where the water heater is located, or combustion air is taken from one of the areas listed, the contaminates must be removed immediately or the intake pipe must be relocated to another area.

Ensure the Water heater Cabinet is Closed

Ensure the water heater cabinet is closed. Tighten the two upper and lower screws to secure it. The cabinet must be closed while the water heater is running.

Check the Power Source

Make sure the power cord is properly connected. The main power line is connected to the manual switch box inside the water heater.

Check the Status of the Control Panel

Observe the Control Panel to ensure the water heater is powered on, and to check for any error codes. Clear any debris from the panel.

Check Exhaust Vent and Intake Pipe Terminations

Verify that the water heater exhaust vent and intake pipe terminations are clean and free of obstructions. Remove any debris from the exhaust vent or intake pipe openings. If removing the debris does not allow the water heater to operate correctly, contact your qualified service technician to inspect the water heater and the vent system.

B. MONTHLY MAINTENANCE

Check Exhaust Vent and Intake Piping

Visually inspect the exhaust vent for any signs of blockage, leakage, or deterioration of the piping. Inspect the exhaust vent bracing. Ensure bracing is undamaged and in good condition. Notify a qualified service technician immediately if any problems are found.

WARNING !

Failure to inspect the venting system and have it repaired by a qualified service technician can result in vent system failure, causing severe personal injury or death.

Visually inspect the intake piping for any signs of blockage. Inspect the entire length of the intake pipe to ensure piping is intact and all joints are properly sealed. Inspect the intake pipe bracing. Ensure bracing is undamaged and in good condition. Notify a qualified service technician if any problems are found.

Check Pressure Relief Valve

- Visually inspect the primary pressure relief valve and discharge pipe for signs of weeping or leakage.
- If the pressure relief valve often weeps, the expansion tank may not be operating properly. Immediately contact a qualified service technician to inspect the water heater and system.

Check the Condensate Drain System

- While the water heater is running, check the discharge end of the condensate drain tubing. Ensure no flue gas is leaking from the condensate drain tubing by holding your fingers near the opening.
- If you notice flue gas leaking from the opening, this indicates a dry condensate drain trap. If problem persists, contact a qualified service technician to inspect the water heater and condensate line and refill the condensate trap.
- If applicable, check the condensate neutralizer and ensure it is full of condensate neutralizing marble chips.

Cleaning the Air Intake Filter

The air intake filter should be cleaned once a month. If not, the water heater could encounter combustion problems.

To clean the air intake filter:

1. Press the Power button on the control panel to turn off the water heater.
2. Disconnect the power supply from the water heater.
3. If water heater has been operating, wait for it to cool before continuing.
4. Remove the front cover of the water heater cabinet.
5. Pull the filter out of the air intake adapter.
6. Remove the filter from the plastic assembly and clean it with a toothbrush and clean running water.

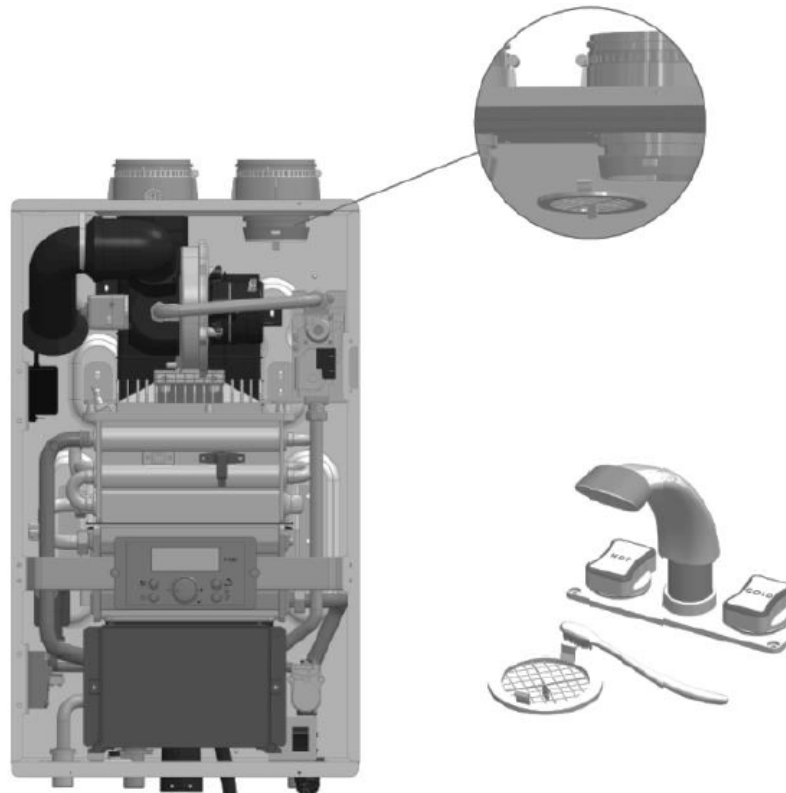

7. Dry the filter completely. Then reinsert the filter into the plastic assembly.
8. Replace the front cover of the water heater cabinet. Reconnect power supply to the water heater.
9. Press the Power button on the control panel to turn on the water heater.

C. 6 MONTH MAINTENANCE

Check Primary and Gas Piping

- Remove the water heater cover and perform a gas leak inspection following the Operating Instructions, page 2, of this manual. If gas odor or leak is detected, follow the procedures on page 2. Call a qualified service technician.
- Visually inspect for leaks around the internal water heater water connections and around the heat exchanger.
- Visually inspect the external system piping, circulators, and system components and fittings. Immediately call a qualified service technician to repair any leaks.

WARNING !

Have leaks fixed at once by a qualified service technician. Failure to comply could result in substantial property damage, severe personal injury, or death.

Operate Pressure Relief Valve

- Before proceeding, verify that the relief valve outlet has been piped to a safe place of discharge, avoiding any possibility of scalding from hot water.
- Shut power off to the water heater. To avoid scalding, wait for water heater to cool before operating the relief valve.

WARNING !

To avoid water damage or scalding due to relief valve operation, a discharge line must be connected to the valve outlet and directed to a safe place of disposal. This discharge line must be installed by a qualified service technician or heating/plumbing installer in accordance with the water heater installation manual.

The discharge line must be terminated so as to eliminate possibility of severe burns or property damage should the valve discharge.

- Lift the relief valve lever. If water flows freely, release the lever and allow the valve to seat. Watch the end of the relief valve discharge pipe to ensure that the valve does not weep after the line has had time to drain. If the valve weeps, lift the lever again to attempt to clean the valve seat. If the valve does not properly seat and continues to weep, contact a qualified service technician to inspect the valve and system.
- If water does not flow from the valve when you completely lift the lever, the valve or discharge line may be blocked. Immediately shut the water heater down per instructions on page 2 and call a qualified service technician to inspect the valve and system.
- If relief valve seats properly, restore power to the water heater. Observe operation for five minutes and ensure it operates properly.

D. ANNUAL MAINTENANCE

Check the Burner

The burner should be checked and cleaned only by a qualified service technician.

Cleaning the Cold Water Inlet Filter (Draining the Water Heater)

The Cold Water Inlet Filter should only be cleaned by a qualified service technician.

Flushing the Water Heater

Flushing the Water Heater heat exchanger is a complicated procedure that should only be performed by a qualified service technician.

NOTE: Improper maintenance WILL VOID water heater warranty.

PART 4 TROUBLESHOOTING

To save time and money, review the following initial diagnostic steps before calling for service.

Problem	Possible Solution
Burner Does Not Ignite	<p>Make sure that the ON/OFF button on the Control Panel is ON</p> <p>If the display on the Control Panel is blank, make sure the power cord is plugged in and 3A fuses on the main controller in the water heater are good.</p> <p>Make sure that the water heater is supplied with water. The unit activates when inlet water flow sensor detects flow over 0.5 gpm.</p> <p>Make sure the cold and hot water lines are not plumbed in reverse.</p> <p>Ensure the cold water and gas supply lines are open.</p> <p>Make sure the water lines are not frozen.</p>
Water is Not Hot Enough	<p>Ensure the temperature setting on the water heater is not too low.</p> <p>Ensure the filter in the cold water supply line is not clogged with debris.</p> <p>Make sure the water heater is connected to the correct gas supply.</p> <p>Check that supply and manifold gas pressures are in accordance with specification.</p> <p>Ensure the water flow sensor with three wires is properly connected on the top of the heat exchanger.</p>
Water is Too Hot	<p>Ensure the temperature setting is not too hot.</p> <p>Ensure the filter in the cold water supply line is not clogged with debris.</p> <p>Make sure the water heater is connected to the correct gas supply.</p>
Hot water temperature fluctuates at tap	<p>Ensure the filter in the cold water supply line is not clogged with debris.</p> <p>Make sure the water heater is connected to the correct gas supply.</p> <p>Ensure the supply gas pressure is sufficient.</p>
The blower continues to operate after combustion stops	<p>This is normal. The blower operates for one minute after combustion has stopped to vent the remaining exhaust gas from the flue.</p>
Cannot change the DHW Mode setpoint above 120°F	<p>This is a safety device to prevent scalding. Hot water temperature over 125°F can cause instant severe burns or death.</p>
The water heater makes abnormal sounds during operation	<p>There is a leak of combustion gas between the sealed chamber and exhaust tube inside the unit.</p> <p>Ensure the venting installation complies with the installation manual.</p> <p>Ensure gas supply pressure is sufficient. Insufficient gas pressure will cause unstable burner flame and noise.</p>

WARNING !

This water heater is equipped with a blocked vent shutoff system. If Error Codes Er:29, Er:41, or Er:94 occur, turn off the gas valve at the manual shutoff. Check the vent terminations for obstructions. If no obstructions are found, reset the water heater by pressing the power button. If the error continues to occur, call a qualified service technician or the gas supplier to check the water heater. Failure to follow these instructions could result in property damage, personal injury, or death.

